

TABLE OF CONTENTS

General:

Table of Contents/Introduction.....	G-1
Phone Numbers for We Energies.....	G-2
One Call Numbers for Location of Utility Facilities	G-2
General Information/New Services	G-3
Residential Electric Facilities Location	G-4
Secondary Voltages	G-5
Overhead Services - Secondary	O-1 to O-19
Underground Services - Secondary	U-1 to U-32
Metering - Secondary	M-1 to M-28
Appendix - Choosing The Proper Meter Socket	i to iv
Meter Mounting Devices - Book 2	D-1 to D-22

INTRODUCTION

The purpose of this manual is to supply essential information to customers, contractors, builders, architects, engineers, and others concerned with the planning of electrical installations.

All information given in this manual is to be used in conjunction with the Company's **Electric Service Rules and Regulations**, on file with the Public Service Commissions of Wisconsin and Michigan. In issuing this manual, the Company is in no way relieving the customer or contractor of his or her responsibility to install the wiring in accordance with the applicable Wisconsin or Michigan State Electrical Codes, as well as local ordinances, or to maintain the wiring and equipment in a safe operating condition. The Company cannot accept any responsibility for the condition of the customer's wiring and equipment.

The information contained herein is general and may not cover all conditions. For new or special cases not specifically covered in this manual, the Company should be consulted.

This edition of the **Electric Service and Metering Manual** supersedes any and all previous editions.

HOW TO USE THIS MANUAL

This Manual is broken into five main sections. Each section has a Table of Contents and General Requirements that apply to that section.

- The section you are reading is the **G** (General) Section, which has the main Table of Contents, phone numbers for We Energies, and provides general information.
- Sections **O & U** (Overhead & Underground) provide the installation details of the equipment for overhead and underground services respectively. They show the equipment layout, critical dimensions and service drop or lateral terminations.
- The **M** (Metering) Section should then be consulted for the wiring of the service equipment. This section is organized by type of service, overhead or underground, 1Ø or 3Ø, and ampacity. The metering sequence to be followed is given after the title block. This section references pages in the **D** Section for that specific metering installation.
- The **D** (Devices) Section lists all the approved termination and metering equipment and is arranged similar to the **M** Section. Only equipment listed in the **D** Section is to be used.

COMPANY CONTACT DIRECTORY

COMPANY WEBSITE

we-energies.com

GENERAL CUSTOMER SERVICE

Residential: 1-800-242-9137

EMERGENCY SERVICE & OUTAGE REPORTING:

Electric: 1-800-662-4797

Gas: 1-800-261-5325

ELECTRIC SERVICE RESIDENTIAL

Website: www.we-energies.com/residential/new_construction/index.htm

Phone: 1-262-574-6400

1-866-423-0364

Fax: 1-262-574-6401

Email: co-non-design-central@we-energies.com

ELECTRIC SERVICE COMMERCIAL

Website: www.we-energies.com/contractors

Phone:	Development/Subdivision	Construction/Service
	SE WI: 800-753-9509	SE WI: 866-423-0364
	Fox Valley: 800-753-9509	Fox Valley: 800-972-8856
	Iron Range: 800-562-1050	Iron Range: 800-562-1050

ONE-CALL CENTERS FOR LOCATION OF UTILITY FACILITIES

WISCONSIN - DIGGERS HOTLINE

- Phone numbers include: From Milwaukee area (414) 259-1181
Toll-free 1-800-242-8511 or 811
TTY 1-800-542-2289
- All types of requests are accepted 24 hours a day, 7 days a week, 365 days a year.
- Wisconsin law requires that a minimum of three working days notice be given for any excavation other than emergencies.
- Will accept calls for emergencies, planned excavation, planning information, appointments and overhead information.
- Visit www.diggershotline.com to file online requests.

MICHIGAN - MISS DIG

- Phone number: toll-free 1-800-482-7171 or 811
- Hours of operation 7:00 A.M. - 7:00 P.M. Monday thru Friday. Emergency calls accepted 24 hours a day 7 days a week.
- Michigan law requires that a minimum of three working days notice be given for any excavation other than emergencies.
- Will accept calls for emergencies, planned excavation, appointments and overhead information.
- Visit www.missdig.net to file online requests.

NOTE: These services will only notify members to locate their facilities.

GENERAL INFORMATION

1. Unless otherwise indicated, all items shown on the sketches are to be furnished and installed by the customer.
2. Meters and current transformers will be furnished and maintained by We Energies.
3. **The Customer's service entrance equipment shall match the existing or requested service size.**
4. Only meter mounting devices and service termination equipment listed in Section D of this manual are to be used. The listing of equipment in this manual is not an endorsement or indication of suitability, but only that it is acceptable for installation of our metering equipment and termination of our service lateral conductors as required. It is the responsibility of the customer or their electrical contractor to verify that the equipment is suitable for the installation and that it is installed in accordance with all applicable codes.
5. Application of these standards must be made in accordance with the Company's **Electric Service Rules and Regulations**.
6. Electrical contractors are expected to acquaint themselves with the plans of other trades on the premises being wired so that the meter can be located in accordance with the requirements set forth in this manual.
7. For all new and rewired, one or two family, single-phase residential services rated at 200 amperes or less, We Energies will not provide an outlet location letter with a Guaranteed Available Short Circuit Current (GASCC) or service equipment location sketch. The customer and/or the electrical contractor will be responsible for ensuring outlet locations and service entrance facilities comply with requirements specified in this manual and in accordance with the applicable Wisconsin or Michigan State Electrical Codes and local ordinances. A GASCC value of 10,000 amps is to be used for these services only. **On January 2025, the minimum short circuit current rating for service entrance equipment to be 18,000 amps.**
8. For all new and rewired single-phase residential services rated at 320 amperes, service entrance equipment shall have a minimum short circuit current rating of 22 kA. Accepted service entrance cable may be used where permitted by the applicable Wisconsin or Michigan State Electrical Codes and Local Ordinances.
9. Transfer equipment used with stand-by power plants or generators shall be suitable for intended use and be so designed and installed as to prevent the inadvertent interconnection of normal and stand-by sources of supply in any operation of the transfer equipment. Further, transfer equipment shall be installed such that it is located electrically on the load side of the meter. **Meter mounted transfer switches will not be allowed.** All transfer schemes shall be submitted to the local We Energies job representative for acceptance before installation.
10. The use of approved material, tested and listed by a nationally recognized testing laboratory, and approved methods of installation are requirements of the Wisconsin State Electrical Code by the Wisconsin State Electrical Code Section of the Department of Commerce, and by OSHA for employers, for customer owned electrical service equipment.
11. This manual only covers secondary services. For Primary Services refer to the Electric Service and Metering Manual Addendum **Primary Rate Requirements for Customer Substations**.

NEW SERVICES

1. Before any new electric service can be installed and energized:
 - a. The electrical contractor, building owner or general contractor must be on site to take responsibility for the newly energized service.
 - b. Or We Energies crews must have safe access to the service's main disconnect.

Please Note that these requirements are in addition to requirements or contingencies such as, but not limited to, the City OK from the Local Municipal Electrical Inspector (or Affidavit in areas where they are used in place of the City OK), grading, permits and payment of any charges.

2. If the above conditions are not met or the service is deemed unsafe the service lateral may be installed, but the service will not be energized. Our crew will leave a tag on site with a telephone number to call to arrange to have the service energized after the reason(s) for not energizing the service have been corrected.
3. If a service is energized and there is no one on site authorized to take responsibility, the main disconnect will be left in the off position and tagged to indicate that the electric service is energized.

RESIDENTIAL ELECTRIC FACILITIES LOCATION

- The National Electric Safety Code requires an unobstructed working space that extends from the floor or ground to a minimum height of 6 feet, 6 inches. For electrical equipment mounted higher than 6 feet, 6 inches, this space shall extend to the top of the equipment.
- For underground service laterals, the centerline of all meters shall be between 3 and 6 feet from the finished grade.
- For overhead service drops, the centerline of all meters shall be between 4 and 6 feet from the finished grade.
- There shall be a minimum distance of 3 feet of unobstructed working space, measured from the meter face, in front of all electric and gas meters.
- A 3 foot minimum separation between gas and electric facilities is required.
- The preferred termination of service laterals is on the outside of a building.
- Only approved meter mounting devices and termination equipment are to be used.
- Meter locations shall be free from excessive moisture, vibrations, and heat.

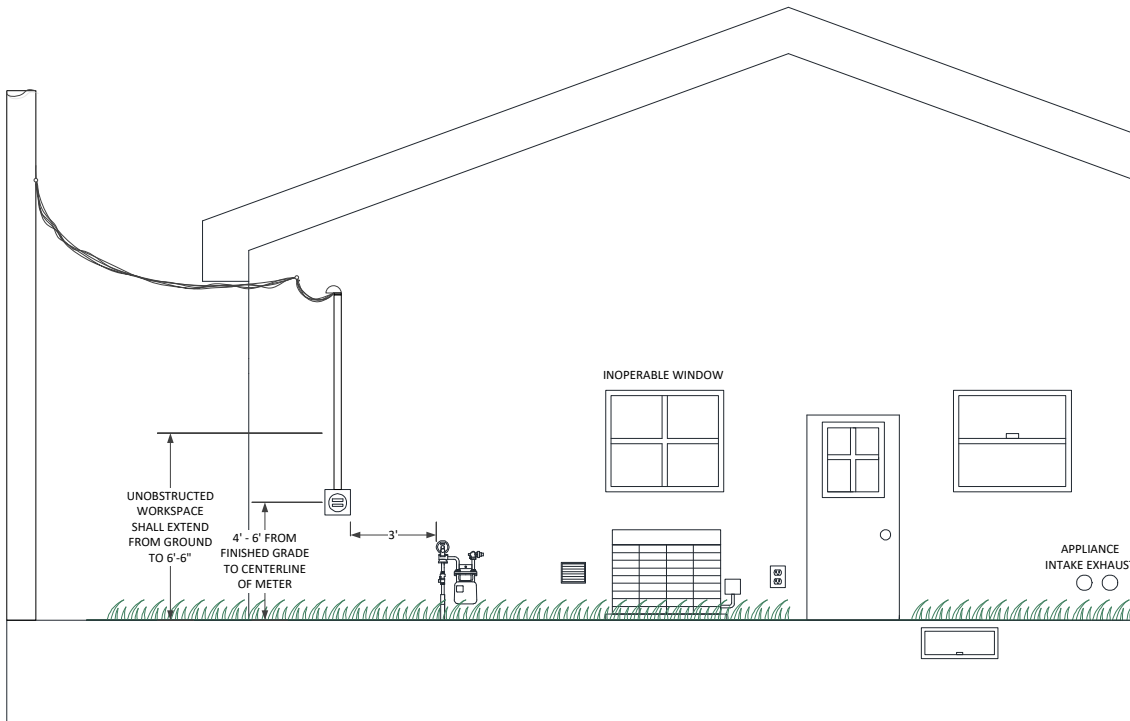
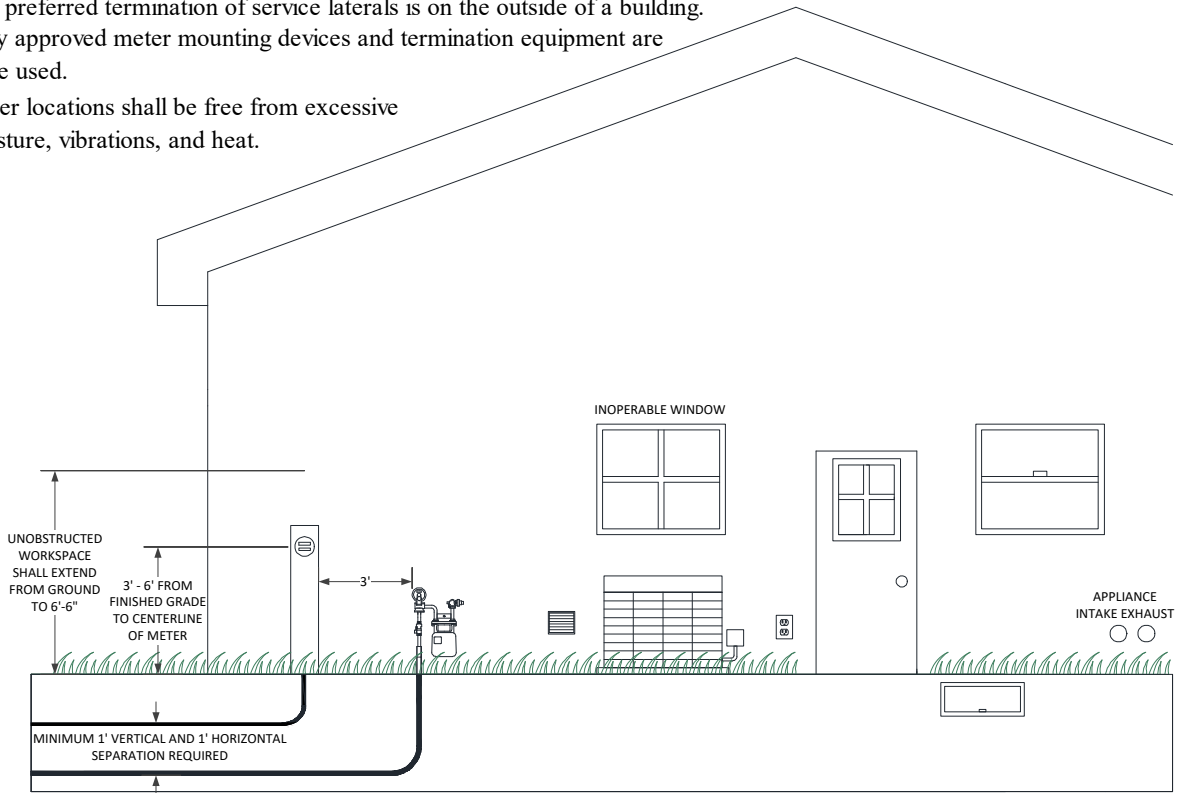

SECONDARY VOLTAGES

The following secondary voltages are generally available from We Energies. **It must be noted that all voltages and ampacities may not be available in all areas.** There may be a charge to extend the necessary facilities to the customer. For some classes of service, especially three phase, availability is also dependent upon the customer's connected load. **The local We Energies job representative must be contacted for availability and cost of service.**

- 120 Volt, 1Ø, 2-Wire..... 30 Amperes maximum
- 120/240 Volt, 1Ø, 3-Wire 800 Amperes maximum
- 208Y/120 Volt, 3Ø, 4-Wire, grounded-wye..... 4000 Amperes maximum
- 480Y/277 Volt, 3Ø, 4-Wire, grounded-wye..... 4000 Amperes maximum
- 208Y/120 Volt, 1Ø, 3-Wire Service..... 100 Amperes/Position maximum
(limited availability)

Secondary voltages no longer provided as new services:

- 240 Volt, 3Ø, 3-Wire Service, Grounded B Phase
- 480 Volt, 3Ø, 3-Wire Service

For services greater than 1600 Amperes and for services using 100% rated Breakers, the Percent Load Factor needs to be calculated as follows:

$$\% \text{ Load Factor} = \frac{\text{Average Load of Daily Cycle}}{\text{Daily Maximum 1 Hour Average}} \times 100$$

Where: The "Average Load of Daily Cycle" is equal to the sum of the average hourly current (in amperes) in a 24 hour period divided by 24.
The "Daily Maximum 1 Hour Average" is equal to the highest average hourly current (in amperes).

Once the % Load Factor has been determined, provide the % Load Factor with your service application.

If a high load factor is expected, an engineering analysis may be required. Please contact the local We Energies job representative if the load factor is expected to be higher than 80%.

OVERHEAD SERVICES - SECONDARY

General requirements for overhead service	O-2
Names of parts for overhead service	O-3
Service attachment on an unguyed service mast	O-4
Height of service head above support on an unguyed service mast	O-5
Service attachment on a guyed service mast.....	O-6
Service attachment on a guyed support stud	O-7
• Pitched roof.....	O-7
• Flat roof.....	O-8
Service attachment on a building.....	O-9
• With brick or stone veneer	O-9
• With wood, aluminum, stucco, or similar siding 0-320 amperes.....	O-10
• Brick or metal building with single or paralleled service entrances.....	O-11
• With bus duct service entrance and indoor metering.....	O-12
Service entrance on a private metering pole	O-13
• 0-320 amperes	O-13
• With outdoor current transformers and a transfer switch 1-phase or 3-phase, 201-800 amperes for farm services only	O-14
Service entrance to a mobile home.....	O-15
• 1-Phase, 120/240 volts, 0-200 amperes, 1 meter.....	O-15
Temporary service for a construction site	O-16
• (0-320 amps).....	O-16
Service to a telecommunication company.....	O-17
• 1-Phase, 120 volts, 0-30 amperes	O-17
Service to a telephone co. pole mounted dryer	O-18
• 1-Phase, 120 volts, 0-30 amperes	O-18
Service termination in a multi-position meter socket.....	O-19
• 1Ø, 120/240 volts, 0-200A per meter, 2-6 meters.....	O-19

GENERAL REQUIREMENTS FOR OVERHEAD SERVICE

Service Drops, Attachments, Supports, and Entrances

1. All service drops are furnished and installed by the Company.
2. In all installations except those stated in the **Rules and Regulations for Electric Service**, the customer shall verify the proper location of the service head and service drop from the Company, which will furnish this information in writing upon request.
3. In all cases, an adequate support for the service drop attachment and service drop shall be provided by the customer. The Company furnishes attachments and will provide information as to the pounds of pull that the service drop support must be designed for or withstand.
4. Typical installations for various service voltages and ampere capacities are shown in succeeding pages. Unusual installations require special consideration and the Company shall be consulted in all cases.
5. The service head is to be located at a height such that the service drop conductors can be dead-ended below the service head and still maintain proper clearance above ground, but they are not to be installed higher than 30' above ground.
6. When 1-phase and 3-phase secondary service is furnished to one building, the service heads shall be spaced approximately 18" apart when installed at the same height. If installed vertically, they shall be spaced approximately 3' apart with the 1-phase head located above the 3-phase head.
7. **Only power service-drop conductors shall be permitted to be attached to a service mast (NEC 230.28).** Other utilities such as telephone or cable TV shall not be attached to the service mast.
8. All unsupported conduit extending above the roofline shall be made of a metallic conduit. See the table on page O-5 for types of conduit and height of service head above support on an unguyed service mast for acceptable requirements.
9. **For paralleled service entrances, the conductors must be connected to the same bus before metering. Paralleled service entrances shall not be routed to separate meter sockets.**

Grounding

1. Grounding shall be in accordance with all applicable codes.
2. Stainless steel (A.I.S.I. 302, 304, or 416) ground rods are recommended where ground rods must be installed in the vicinity of buried galvanized rigid conduit, to minimize the possibility of corrosion.
3. The grounding electrode conductor shall not be run through the meter socket or transocket.
4. Bonding to other systems shall not be done on or within a metering enclosure unless a means of bonding, intended for inter-system bonding, is furnished as part of the metering enclosure (PSC 114.099(C)).

Metering

1. This section details the requirements for overhead service drop attachments and connections. Refer to the Metering Section of this manual for details of the metering requirements for each installation.

NAMES OF PARTS FOR OVERHEAD SERVICE

Customer furnishes and installs:

- A. Service entrance conductors
- B. Service head
- C. Service mast
- D. Company listed metering equipment
- E. Service equipment

Company furnishes and installs:

- F. Service drop conductors
- G. Watthour meter
- H. Connectors

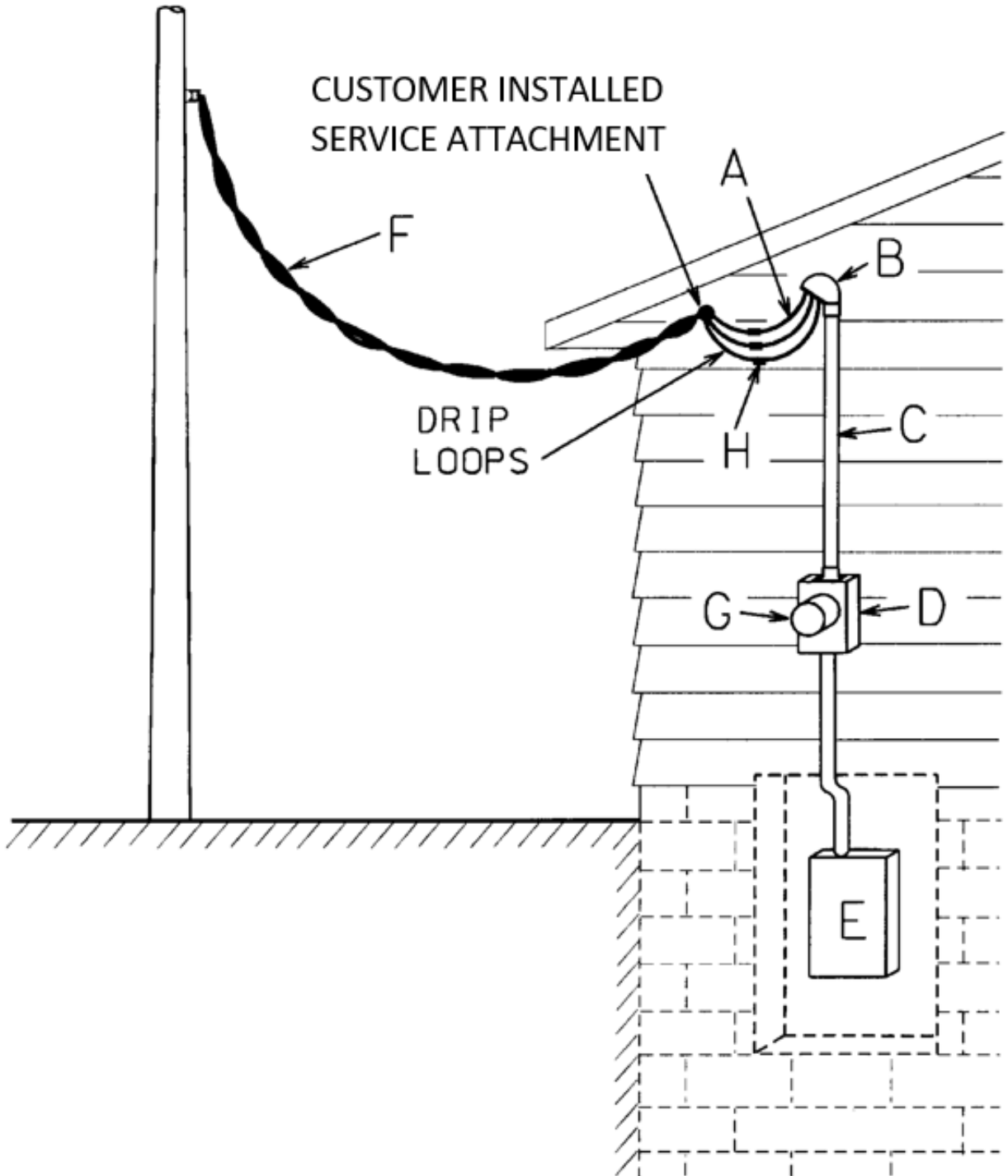

SERVICE ATTACHMENT ON AN UNGUYED SERVICE MAST

Customer furnishes and installs:

1. Service head.
2. Service mast, 2" minimum rigid metallic conduit (see Note 2).
3. Neoprene collar and flash plate.
4. Service entrance conductors (see Note 3).
5. Split ring type conduit supports.
6. Wood blocking.

Company furnishes and installs:

7. Service attachment (clamp type wireholder).
8. Service connectors.
9. Service drop.

Notes:

1. Contact the Local Municipal Inspector for approval of service mast that extend more than 3' (914 mm) above the roof.
2. That portion of service mast above uppermost conduit support shall be a continuous length without couplings. Refer to Sheet O-5 for maximum height of service head above support.
3. Service entrance conductors shall extend at least 18" beyond the service head to permit proper connection to the Company's conductors.
4. For rewires where it is not possible to install Item # 6 (wood blocking) a Heavy Duty Flash Plate is to be used.
5. Only the electric service drop shall be attached to the service mast.

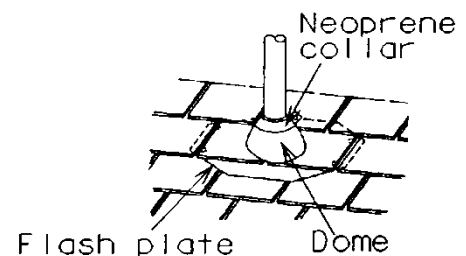
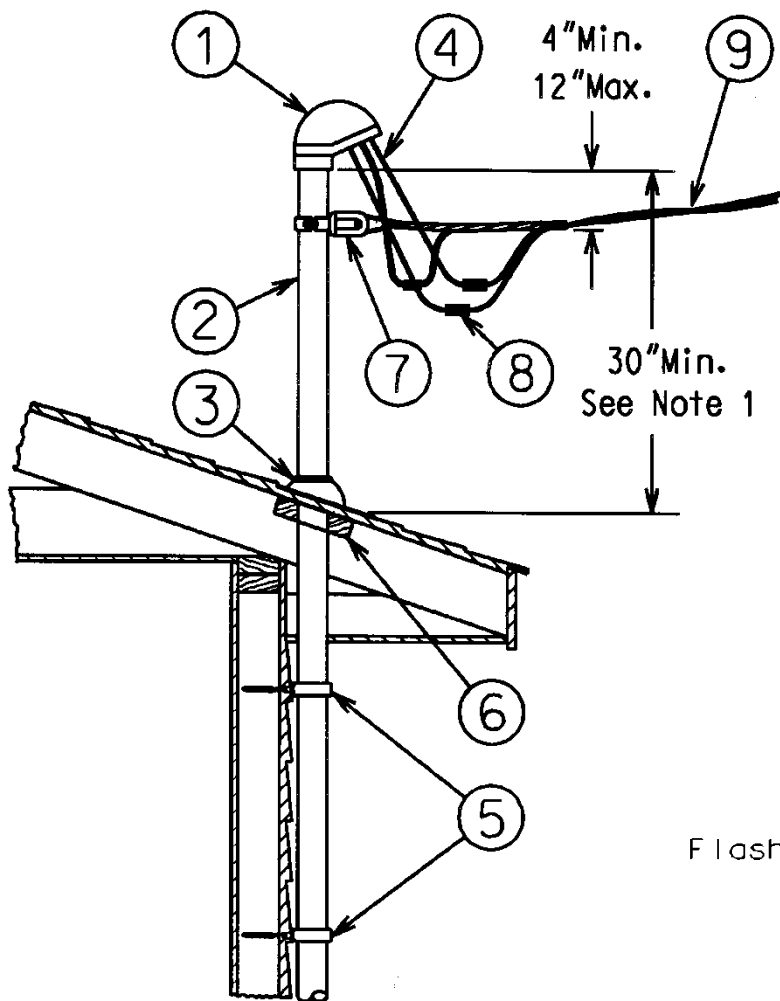

Flash Plate
Detail

HEIGHT OF SERVICE HEAD ABOVE SUPPORT ON AN UNGUYED SERVICE MAST

Contact the local Company office if there is a need to extend the conduit beyond 8'.

		Service Drop Length	Maximum Height of Service Head		
			2" Conduit	2-1/2" Conduit	3" Conduit
Rigid Metal Steel Conduit	#2 Aluminum Triplex (1Ø, 100 Amp. Service)	30'	8'- 0"	8'- 0"	8'- 0"
		40'	6'-11"	8'- 0"	8'- 0"
		50'	5'-10"	8'- 0"	8'- 0"
		60'	5'- 1"	8'- 0"	8'- 0"
		70'	4'- 7"	7'- 6"	8'- 0"
		80'	4'- 1"	6'- 8"	8'- 0"
	90-120'	3'- 2"	4'-11"	7'- 8"	
	#1/0 Aluminum Triplex (1Ø, 200 Amp. Service)	30'	7'- 8"	8'- 0"	8'- 0"
		40'	6'- 1"	8'- 0"	8'- 0"
		50'	5'- 0"	8'- 0"	8'- 0"
		60'	4'- 4"	7'- 2"	8'- 0"
		70'	3'-11"	6'- 4"	8'- 0"
80'		3'- 7"	5'- 8"	8'- 0"	
90-120'	2'- 9"	4'- 2"	6'- 5"		
Rigid Metal Aluminum Conduit	#2 Aluminum Triplex (1Ø, 100 Amp. Service)	30'	4'- 1"	6'-10"	8'- 0"
		40'	3'- 4"	5'- 5"	8'- 0"
		50'	2'-11"	4'- 8"	6'-11"
		60'	2'- 7"	4'- 1"	6'- 0"
		70'	*	3'- 8"	5'- 4"
		80'	*	3'- 4"	4'- 9"
	90-120'	*	2'- 7"	3'- 8"	
	#1/0 Aluminum Triplex (1Ø, 200 Amp. Service)	30'	3'- 8"	6'- 0"	8'- 0"
		40'	3'- 0"	4'-10"	7'- 2"
		50'	2'- 7"	4'- 0"	5'-11"
		60'	*	3'- 6"	5'- 1"
		70'	*	3'- 2"	4'- 7"
80'		*	2'-11"	4'- 2"	
90-120'	*	*	3'- 2"		
Intermediate Steel Conduit	#2 Aluminum Triplex (1Ø, 100 Amp. Service)	30'	6'- 0"	8'- 0"	8'- 0"
		40'	4'-10"	8'- 0"	8'- 0"
		50'	4'- 2"	7'- 3"	8'- 0"
		60'	3'- 8"	6'- 4"	8'- 0"
		70'	3'- 4"	5'- 7"	8'- 0"
		80'	3'- 0"	5'- 0"	7'- 1"
	90-120'	*	3'- 9"	5'- 3"	
	#1/0 Aluminum Triplex (1Ø, 200 Amp. Service)	30'	5'- 2"	8'- 0"	8'- 0"
		40'	4'- 4"	7'- 6"	8'- 0"
		50'	3'- 7"	6'- 2"	8'- 0"
		60'	3'- 2"	5'- 4"	7'- 7"
		70'	2'-11"	4'- 9"	6'- 8"
80'		2'- 8"	4'- 4"	6'- 1"	
90-120'	*	3'- 3"	4'- 5"		

		Service Drop Length	Dimensions Above Ground	
			2-1/2" Conduit	3" Conduit
Rigid Metal Steel Conduit	#6 Aluminum Duplex	30'	20'- 4"	31'- 0"
		40'	15'- 8"	25'- 9"
		50'	12'-10"	20'-10"
		60'	11'- 1"	18'- 1"
		70'	**	15'- 7"
		80'	**	14'- 0"
		90'	**	12'- 9"
		100'***	**	11'- 8"

* Conduit not adequate for 30" minimum requirement.
 ** Conduit not adequate for 10' minimum clearance.
 *** Maximum allowable service drop length.

SERVICE ATTACHMENT ON A GUYED SERVICE MAST

Customer furnishes and installs:

1. Service head.
2. Service mast. 2" minimum rigid metallic conduit (see Note 1).
3. Service entrance conductors (see Note 2).
4. Neoprene collar and flash plate.
5. Split ring type conduit supports.
6. Galvanized guy wire and necessary attachments
(1/4" minimum, 3 or 7 strands).

Company furnishes and installs:

7. Service attachment
(clamp type wireholder).
8. Service connectors.
9. Service drop.

Notes:

1. That portion of service mast above uppermost conduit support shall be a continuous length without couplings.
2. Service entrance conductors shall extend at least 18" beyond the service head to permit proper connection to the Company's conductors.
3. Only the electric service drop can be attached to the service mast.

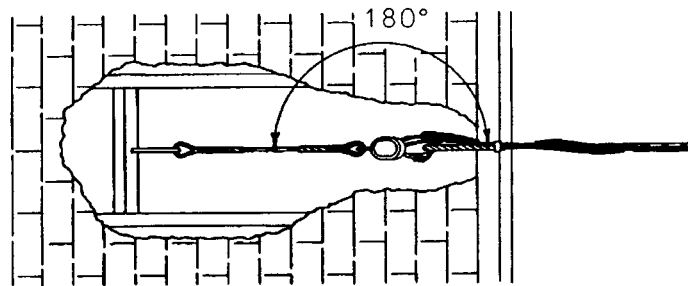

Top View

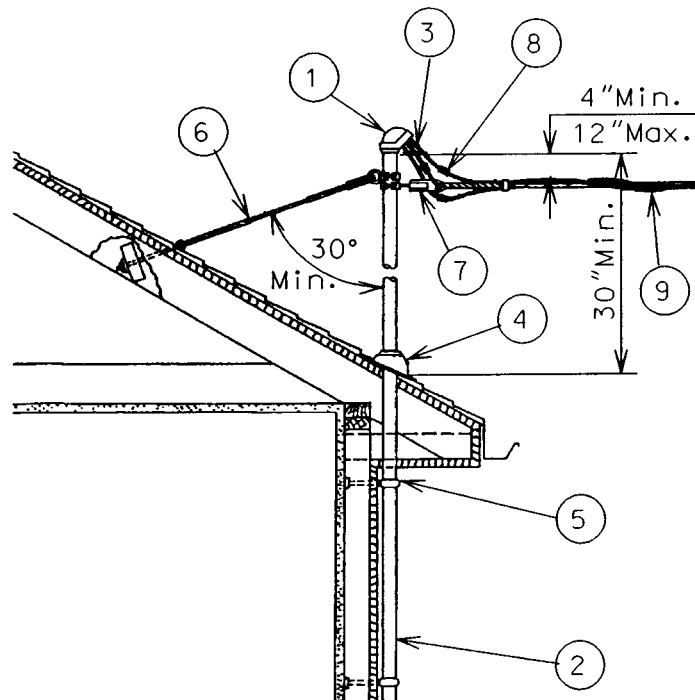

SERVICE ATTACHMENT ON A GUYED SUPPORT STUD PITCHED ROOF

Customer furnishes and installs:

1. Service head.
2. Service entrance conduit.
3. Service entrance conductors (see Note 2).
4. Steel channel or equivalent securely fastened to building wall (see Note 1).
5. Galvanized guy wire and necessary attachments (1/4" minimum, 3 or 7 strands).

Company furnishes and installs:

6. Service attachment.
7. Service connectors.
8. Service drop.

Notes:

1. Customer shall notch roof overhang to accommodate support stud. Stud to have sufficient strength to withstand maximum loading. Install service entrance conduit close to building wall.
2. Service entrance conductors shall extend at least 18" beyond the service head to permit proper connection to the Company's conductors.
3. Only the electric service drop can be attached to the service mast.

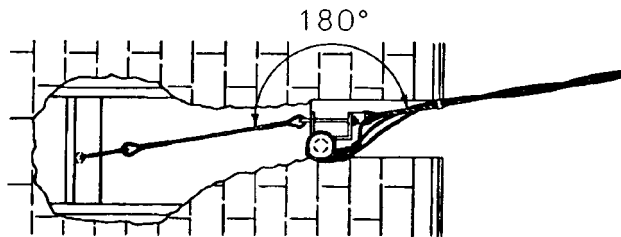

Top View

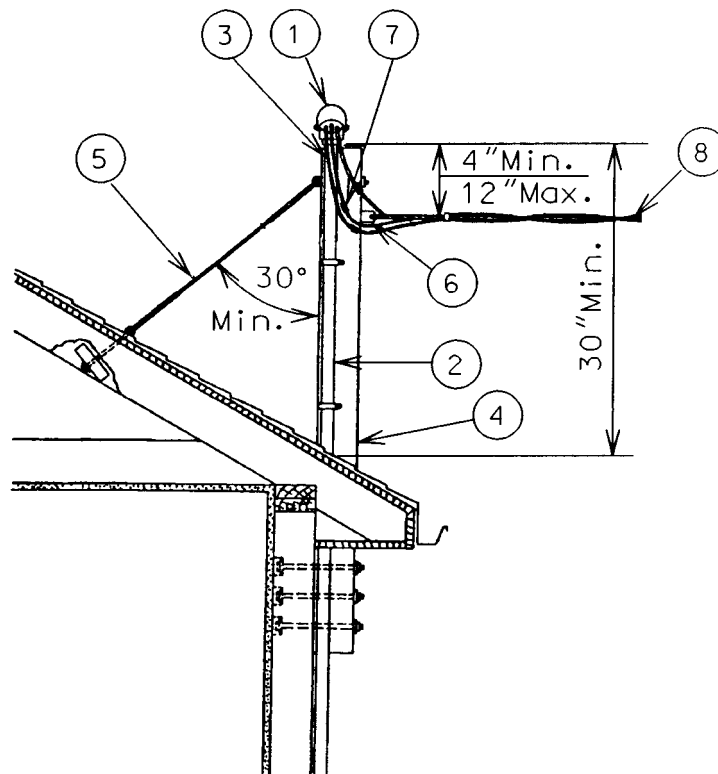

SERVICE ATTACHMENT ON A GUYED SUPPORT STUD FLAT ROOF

Customer furnishes and installs:

1. Service head.
2. Service entrance conduit.
3. Service entrance conductors (see Note 1).
4. Steel channel or equivalent securely fastened to building wall.
5. Galvanized guy wire and necessary attachments
(1/4" minimum, 3 or 7 strands).

Company furnishes and installs:

6. Service attachment.
7. Service connectors.
8. Service drop.

Notes:

1. Service entrance conductors shall extend at least 18" beyond the service head to permit proper connection to the Company's conductors.
2. Only the electric service drop can be attached to the service mast.

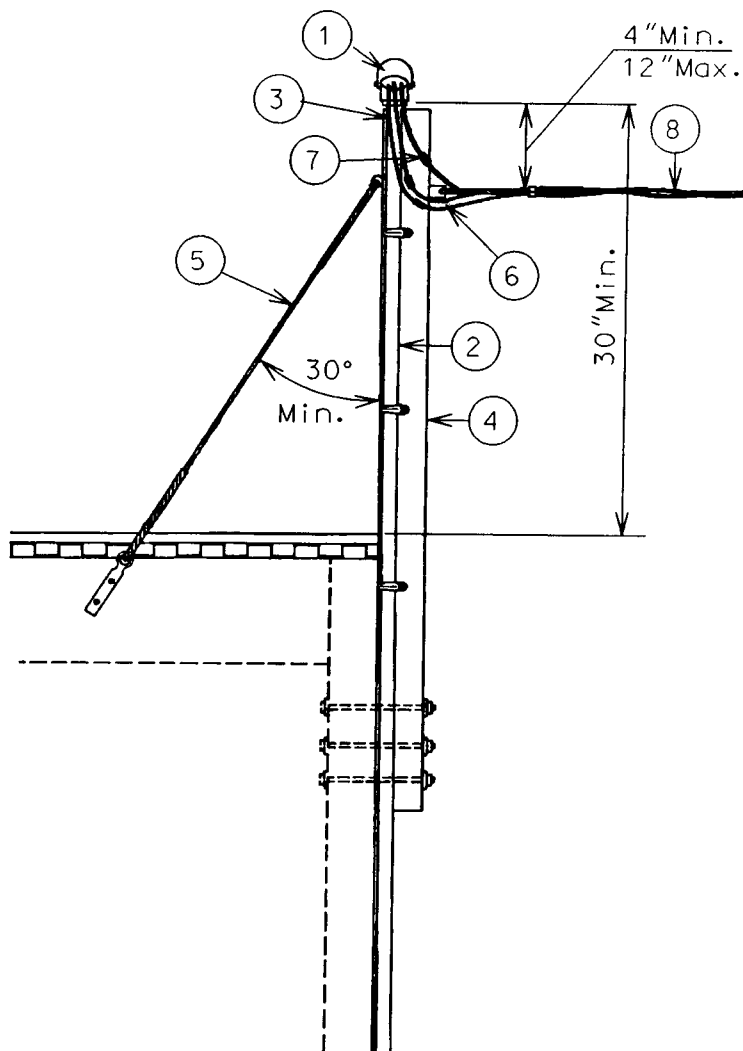

SERVICE ATTACHMENT ON A BUILDING WITH BRICK OR STONE VENEER

Customer furnishes and installs:

1. Service head.
2. Service entrance conduit.
3. Service entrance conductors (see Note 2).

Company furnished and installs:

5. Service connectors.
6. Service drop (#2 & #1/0 triplex only).

Company furnishes and Customer installs:

4. Service attachment. "T" type bracket installed with 3/8" x 4" lag screws (see Note 1).

Notes:

1. The customer may provide a bracket of the type shown below. Install a steel strap from the hole in the bracket to an adjacent studding for service drops that pull off at an angle.
2. Service entrance conductors shall extend at least 18" beyond the service head to permit proper connection to the Company's conductors.

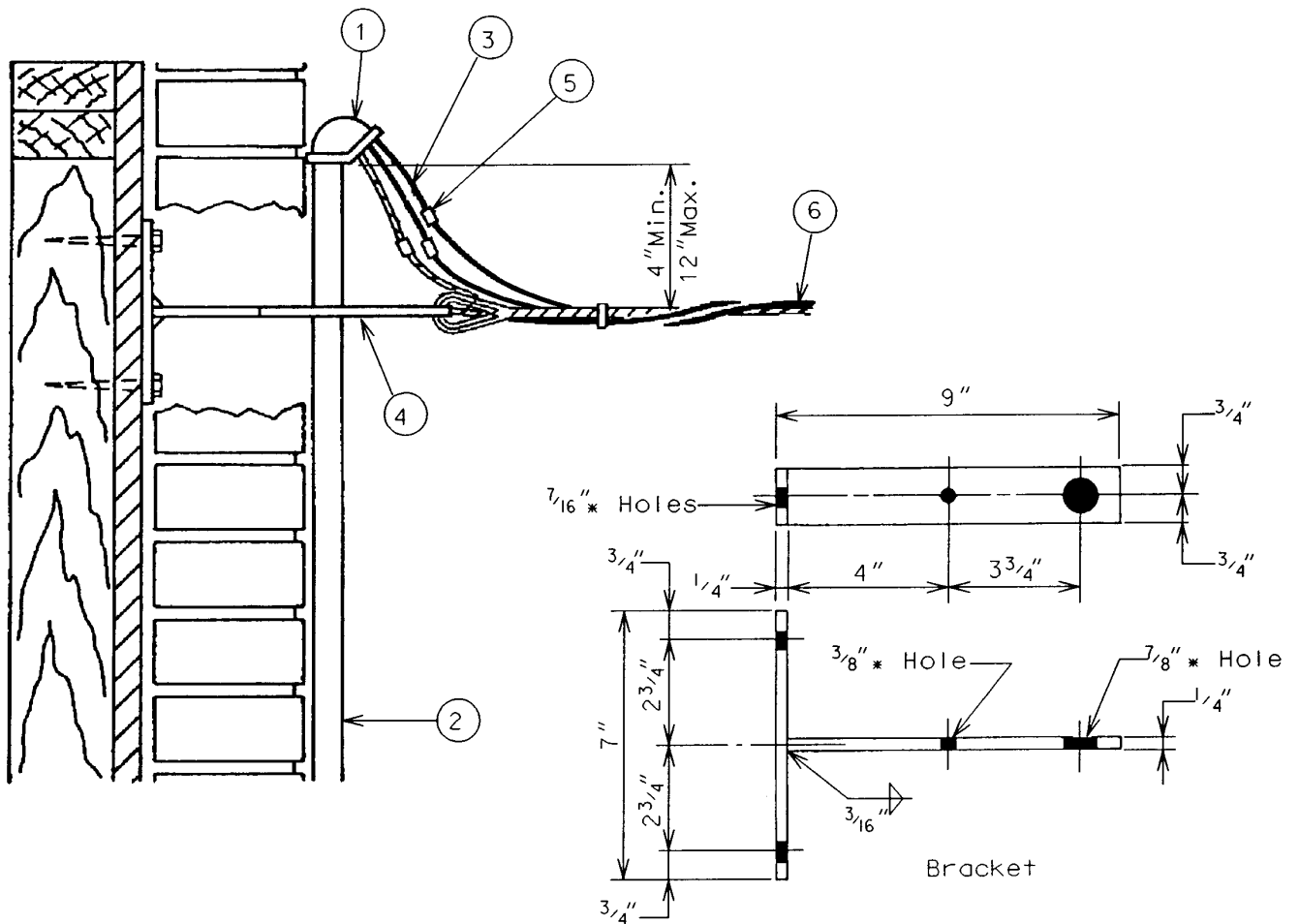

**SERVICE ATTACHMENT ON A BUILDING
WITH WOOD, ALUMINUM, STUCCO OR SIMILAR SIDING
0-320 AMPERES**

Obtain acceptance for installations larger than 200 amperes from the local Company office.

Customer furnishes and installs:

1. Service head.
2. Service entrance conduit.
3. Service entrance conductors (see Note 2).

Company furnishes and installs:

4. Service attachment (see Note 1).
5. Service connectors.
6. Service drop.

Notes:

1. Customer shall mark location of studs on building.
2. Service entrance conductors shall extend at least 18" beyond the service head to permit proper connection to the Company's conductors.

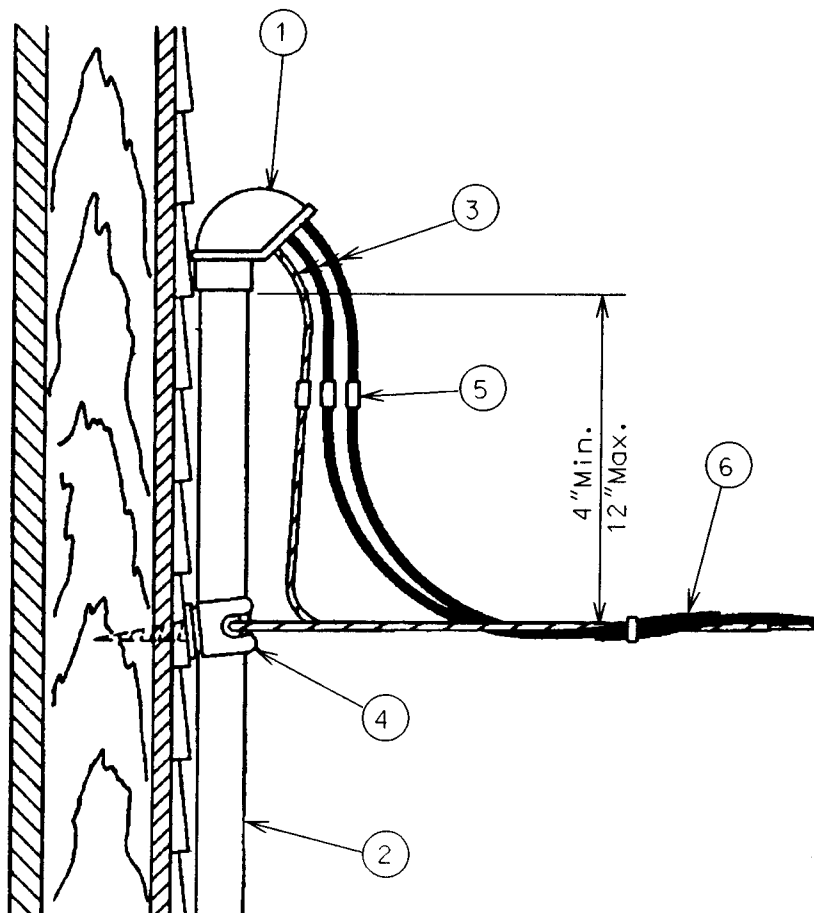

**SERVICE ATTACHMENT ON A BUILDING
BRICK OR METAL BUILDING WITH SINGLE OR PARALLELED SERVICE ENTRANCES**

Customer furnishes and installs:

1. Service head (a maximum of 4).
2. Service entrance conduit.
3. Service entrance conductors (see Note 2).
4. Additional outlet for parallel services if required.

Company furnishes and installs:

6. Service attachment.
7. Service connectors.
8. Service drop.
9. Alternate service attachment if required.

Company furnishes and Customer installs:

5. 5/8" spacer bolt with two 4" square flat washers. Washers to be installed on both sides of building wall (see Note 1).

Notes:

1. It shall be the customer's responsibility to provide adequate wall strength to support service drop tensions as provided by the Company.
2. Service entrance conductors shall extend at least 30" beyond the service head to permit proper connection to the Company's conductors.

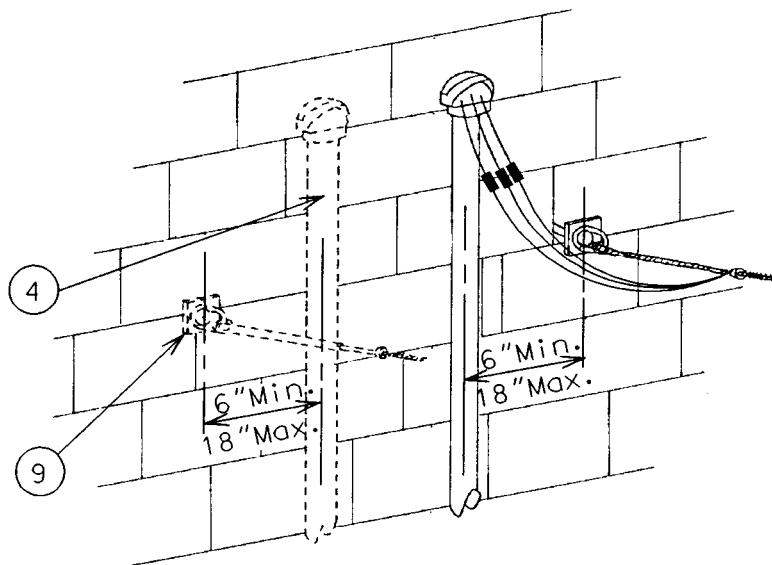
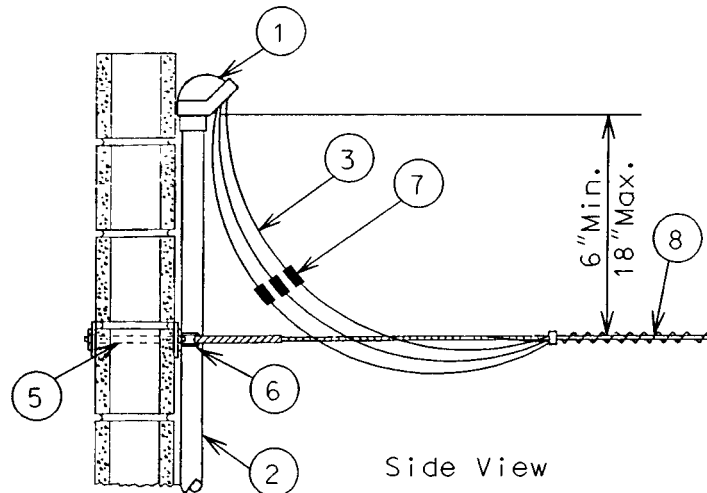

SERVICE ATTACHMENT ON A BUILDING WITH BUS DUCT SERVICE ENTRANCE AND INDOOR METERING

Obtain acceptance and specific details from the local Company office.

Customer furnishes and installs:

1. Service entrance duct (see Note 1).

Company furnishes and Customer installs

2. 5/8" spacer bolt with two 4" square flat washers. Washers to be installed on both sides of building wall (see Note 2).

Company furnishes and installs:

3. Service drop and attachment.
4. Service connectors.

Notes:

1. If the vertical dimension of the bus bars exceed 5-3/4", the customer shall be responsible for taping the top of the bus bars such that not more than 5-3/4" remain exposed.
2. It shall be the customer's responsibility to provide adequate wall strength to support service drop tensions as provided by the Company.

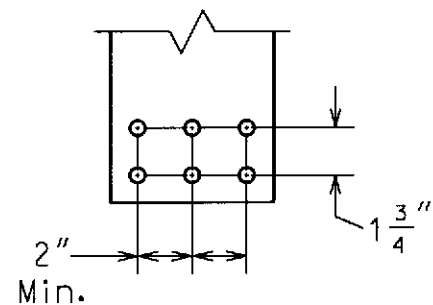
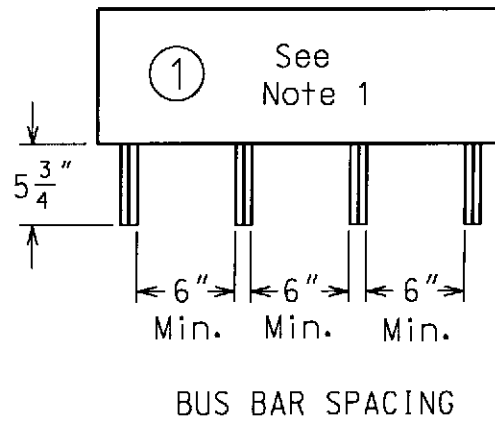
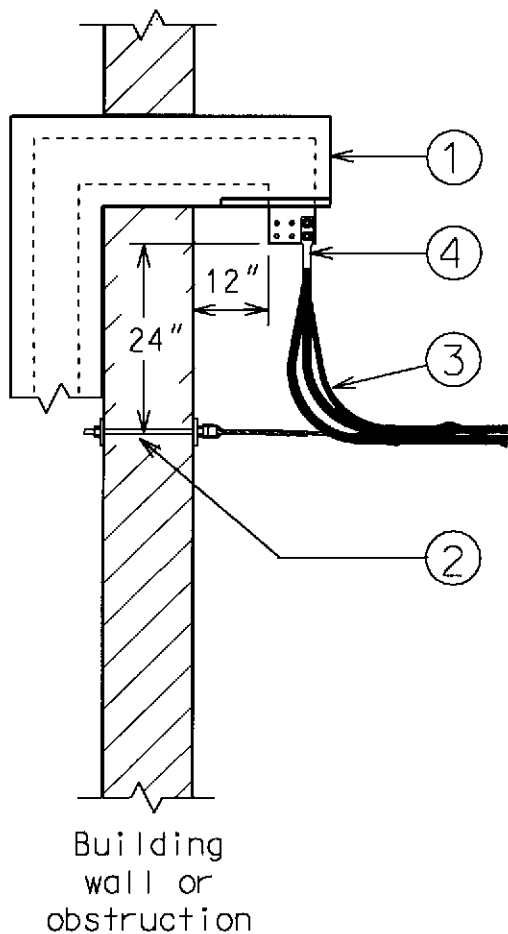

All holes $\frac{9}{16}$ " Dia.

**SERVICE ENTRANCE ON A PRIVATE METERING POLE
0-320 AMPERES**

Customer furnishes and installs:

1. Service heads.
2. Service entrance conduit. Provide mechanical protection to a point 8' above grade.
3. Service entrance conductors (see Note 5).
4. Treated wood pole (see Notes 1 & 2).
5. Secondary pole rack or equivalent.
6. Sub-service conductors (see Notes 1 & 3).
7. Company listed 1-position meter socket (see Note 6).
8. Grounding electrode conductor.
9. Grounding electrode(s) per applicable codes (see Sheet O-2).
10. Weatherproof disconnecting means (see Note 4).

Notes:

1. It may be necessary to guy the meter pole. Customer shall consult the Company to obtain such information as service drop tension and direction so that adequate and effective guying can be installed.
2. Customer shall consult the Company for the class, setting depth and length of pole to be installed. Minimum requirements are class 6, 5' setting depth and 25' length; additional pole height may be required to maintain clearances as specified in the NEC.
3. Other sub-services may be installed where necessary when each is provided with proper service ground.
4. On meter poles where the disconnecting means is installed at some other location, direct grounding of the meter socket is permissible.
5. Service entrance conductors shall extend at least 18" beyond the service head to permit proper connection to the Company's conductors.
6. For farm installations the centerline of the meter shall be 5' above grade. For all other installations, use standard meter mounting height (see M-2).

Company furnishes and installs:

11. Service attachment.
12. Service connectors.
13. Service drop.
14. Watthour meter.

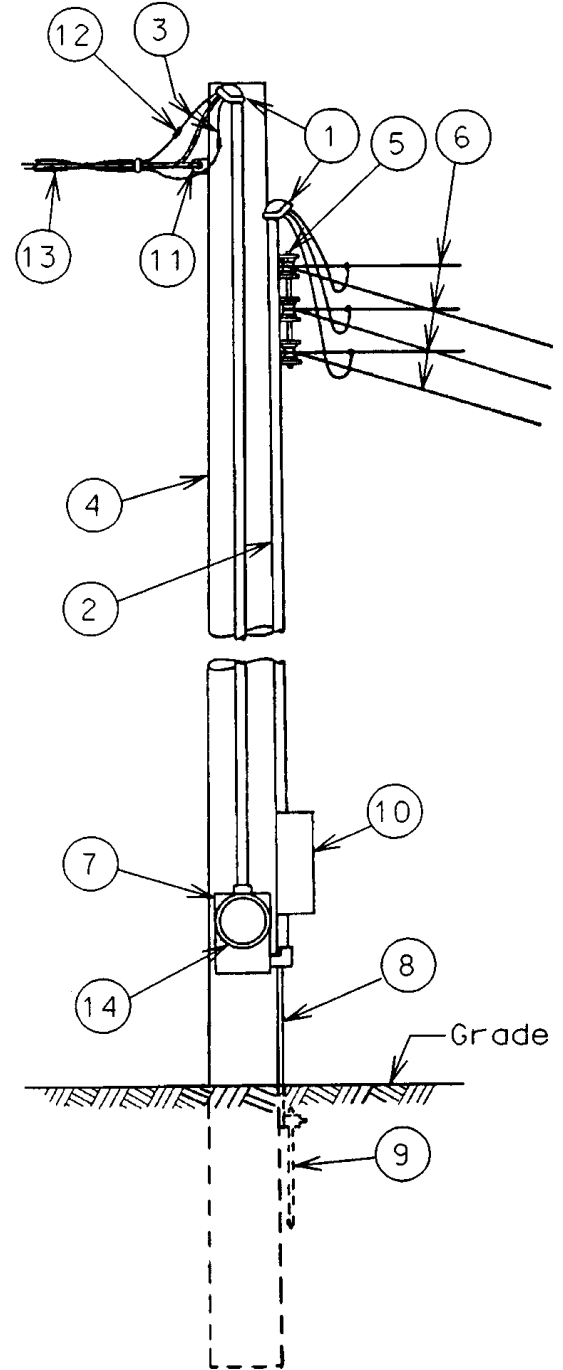

**SERVICE ENTRANCE ON A PRIVATE METERING POLE
WITH OUTDOOR CURRENT TRANSFORMERS AND A TRANSFER SWITCH
1-PHASE OR 3-PHASE, 201-800 AMPERES
FOR FARM SERVICES ONLY**

Obtain acceptance from the local Company office.

Customer furnishes and installs:

1. Transfer switch, UL listed or equivalent.
2. Weatherproof receptacle for generator.
3. Operating handle for transfer switch (grounded).
4. Service entrance conductors (see Note 1 & 2).
5. Service attachment (secondary wireholder or equivalent).
6. Screw type insulator to support neutral conductor.
7. Treated wood pole (see Notes 3 & 4).
8. Grounding electrode(s) per applicable codes (see Sheet O-2).
9. Grounding electrode conductor.
10. Company listed transformer rated meter socket (see Sheet D-17).
11. Conduit (see Note 5).
12. Water-tight entrance connector with neoprene bushing, or weatherhead.

Notes:

1. Service entrance conductors shall extend at least 36" past the bottom of the pole top transfer switch to permit proper connection to the Company's conductors.
2. Underground service entrance conductors and conduit may be substituted for the overhead conductors. If this is done the pole must be accessible by bucket truck and mechanical protection 8' above and 18" below grade, minimum, are required.
3. It may be necessary to guy meter pole. Customer shall consult the Company to obtain such information as service drop tensions and direction so that adequate and effective guying can be installed.
4. Customer shall consult the Company for the class, setting depth and length of pole to be installed. Minimum requirements are class 6, 5' setting depth and 25' height; additional pole height may be required to maintain clearances as specified in the NEC.
5. 1-1/4" galvanized rigid, galvanized intermediate or rigid nonmetallic schedule 40 PVC conduit per NEMA Standard TC-2, and 1-1/4" coupling with 1-1/4" to 1" reducer. Conduit to be securely fastened to pole with standard conduit straps or clamps.

Company furnishes and installs:

13. Service attachment (secondary wireholder or equivalent).
14. Service connectors.
15. Service drop.
16. Current transformers.
17. Metering cable.
18. Watthour meter.

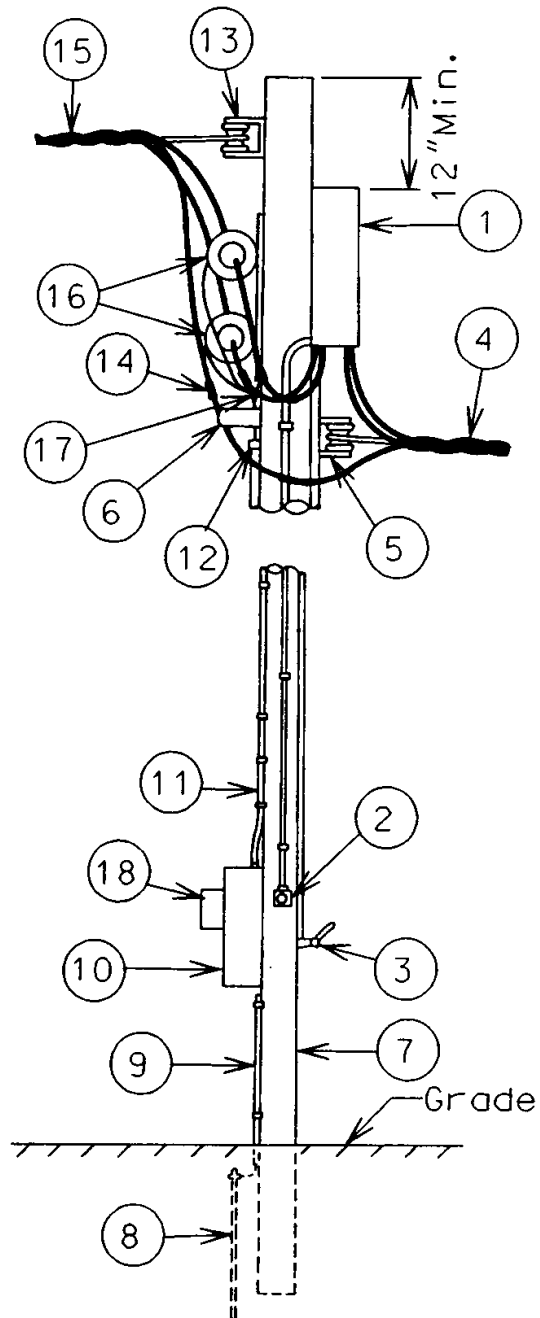

**SERVICE ENTRANCE TO A MOBILE HOME
1-PHASE, 120/240 VOLTS, 0-200 AMPERES, 1 METER**

Customer furnishes and installs:

1. Service head.
2. Service entrance conduits. Provide mechanical protection to a point 8' above grade.
3. Service entrance conductors (see Note 3).
4. Treated wood pole (see Notes 1 & 2).
5. Company listed 4-terminal meter socket.
6. Weatherproof panelboard (see Note 4).
7. Grounding electrode conductor.
8. Grounding electrode(s) per applicable codes (see Sheet O-2).

Company furnishes and installs:

9. Service attachment.
10. Service connectors.
11. Service drop.
12. Watthour meter.

Notes:

1. It may be necessary to guy the meter pole. Customer shall consult the Company to obtain such information as service drop tension and direction so that adequate and effective guying can be installed.
2. Customer shall consult the Company for the class, setting depth and length of pole to be installed. Minimum requirements are class 6, 5' setting depth and 20' length; additional pole height may be required to maintain clearances as specified in the NEC.
3. Service entrance conductors shall extend at least 18" beyond the service head to permit proper connection to the Company's conductors.
4. Article 550 of the *National Electrical Code* covers the special requirements for mobile homes. A few of the requirements are listed below. See the NEC for a complete listing of the requirements.
 - Mobile home service equipment must have a means for providing service to an auxiliary building or electrical equipment located outside the mobile home by a fixed wiring means.
 - It also permits additional 120 Volt, 15 or 20 Amp., GFI protected, receptacles to be installed for equipment located outside of the mobile home.
 - The service or disconnecting means must be with-in sight of and not more than 30' from an exterior wall of the mobile home.
 - All wiring must be installed as per the NEC, State and local ordinances.

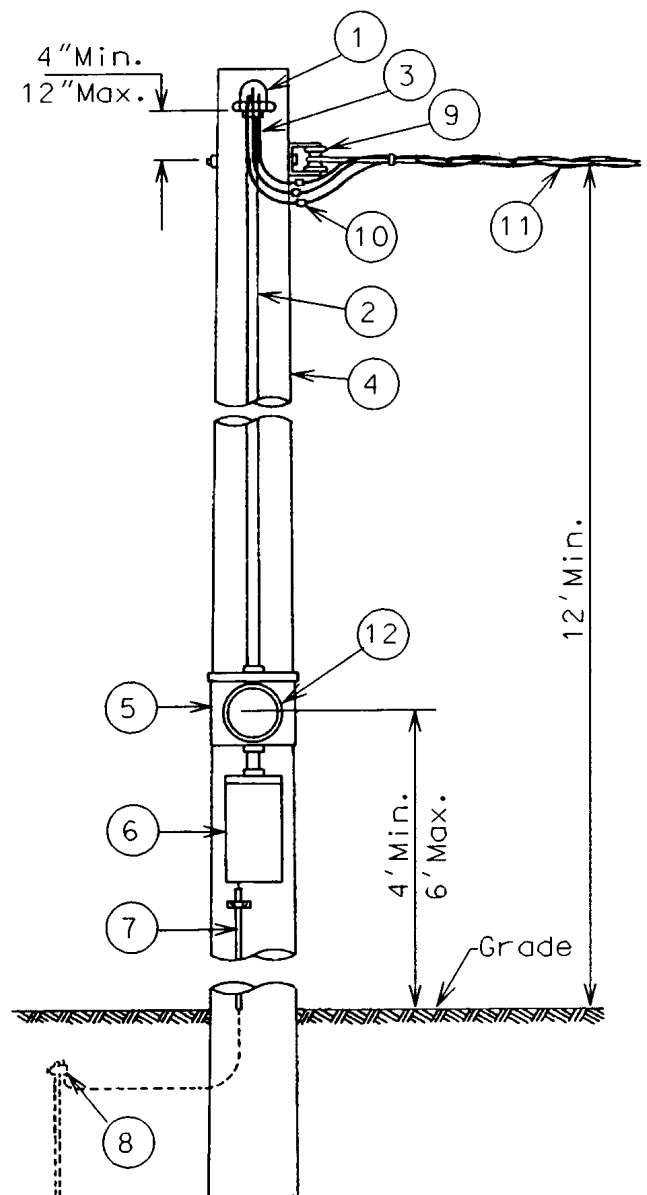

TEMPORARY SERVICE FOR A CONSTRUCTION SITE (0-320 AMPS)

Customer furnishes and installs:

1. Service head.
2. Service entrance conduit.
3. Service entrance conductors (see Note 4).
4. Timber upright (4" x 4" or 6" x 6")
(see Notes 1 & 2).
5. Company listed meter socket (see Note 3).
6. Service switch and distribution panel
(see Note 3).
7. Brace or guy timbers to hold 1000 pounds
load each (see Note 1).
8. Grounding electrode conductor.
9. Grounding electrode(s) per applicable codes
(see Sheet O-2).

Company furnishes and installs:

10. Service attachment (secondary porcelain
screw bracket or equivalent wireholder).
11. Service connectors.
12. Service drop.
13. Watthour meter.

Notes:

1. For temporary service the customer shall install this structure or other Company listed equivalent structure: Utility Service Manufacturing Company Miti-Mast, MM or ML series with catalog numbers suffix "HDB" (for heavy duty back stake). This approval applies only to the meter socket and the strength of the temporary mast, but does not include approval of the disconnecting device or the power outlet.
2. Consult the Company for the location and the required height of the structure.
3. A Company listed temporary service assembly, as listed on Sheet D-6, may be substituted for the meter socket, service switch and distribution panel.
4. Service entrance conductors shall extend at least 30" beyond the service head to permit proper connection to the Company's conductors.
5. For 400A or larger temporary services, construct U-10 at the base of the pole with an approved OH transocket (D-14).

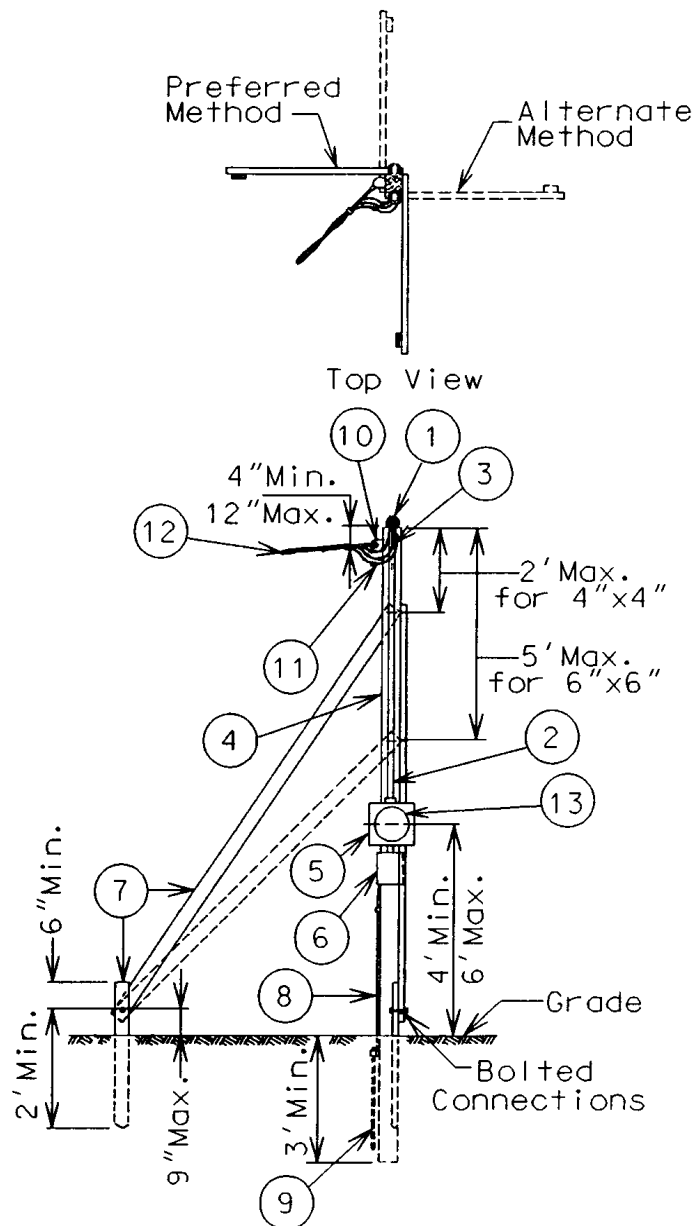

**SERVICE TO A TELECOMMUNICATION COMPANY
1-PHASE, 120 VOLTS, 0-30 AMPERES**

Customer furnishes and installs:

1. Service head.
2. Service entrance conduit (see Note 1).
3. Service entrance conductors (see Note 2).
4. Weatherproof, dead front, fuse or circuit breaker (see Notes 3 & 4).
5. Telecommunication equipment (see Notes 3, 4, 5, 6 & 7).
6. Grounding electrode conductor.
7. Grounding electrode(s) per applicable codes (see Sheet O-2).
8. Company listed meter socket (see Notes 3 & 8).

Company furnishes and installs:

9. Service conductors and connectors from secondary to service entrance conductors.
10. Watthour meter.

Notes:

1. Non-metallic conduit, Schedule 80. If metallic conduit is used, it shall be covered with a non-metallic covering 40" above and 72" below any communications attachments.
2. The service entrance conductors shall extend at least 18" beyond the service head to permit proper connection to the Company's conductors.
3. The disconnect, power supply unit, meter socket, and all other equipment shall be mounted on the same quadrant of the pole.
4. When a unit contains both the service switch and the power supply, installation height shall be in accordance with applicable codes.
5. Unit may not be mounted on any pole on which there are transformers, risers, vertical supply conductors to aerial services, switch handles, traffic signals, capacitor banks or similar fixtures. Additionally, it may not be mounted on a distribution system corner pole.
6. Where mounted on a pole on which a lighting fixture is installed, a clearance of 20" is required to an ungrounded fixture or 4" if fixture is grounded and bonded to the power supply.
7. All installations must conform to the Wisconsin or Michigan State Electrical Code as applicable for clearances, climbing space and working space.
8. Equipment shall be installed such that it is not subject to vehicle or pedestrian traffic. The Company may refuse to allow service on a pole used by We Energies, in this case, use a free standing pedestal or customer owned service pole.
9. Not to be served from a transformer equipped with neutral isolator.

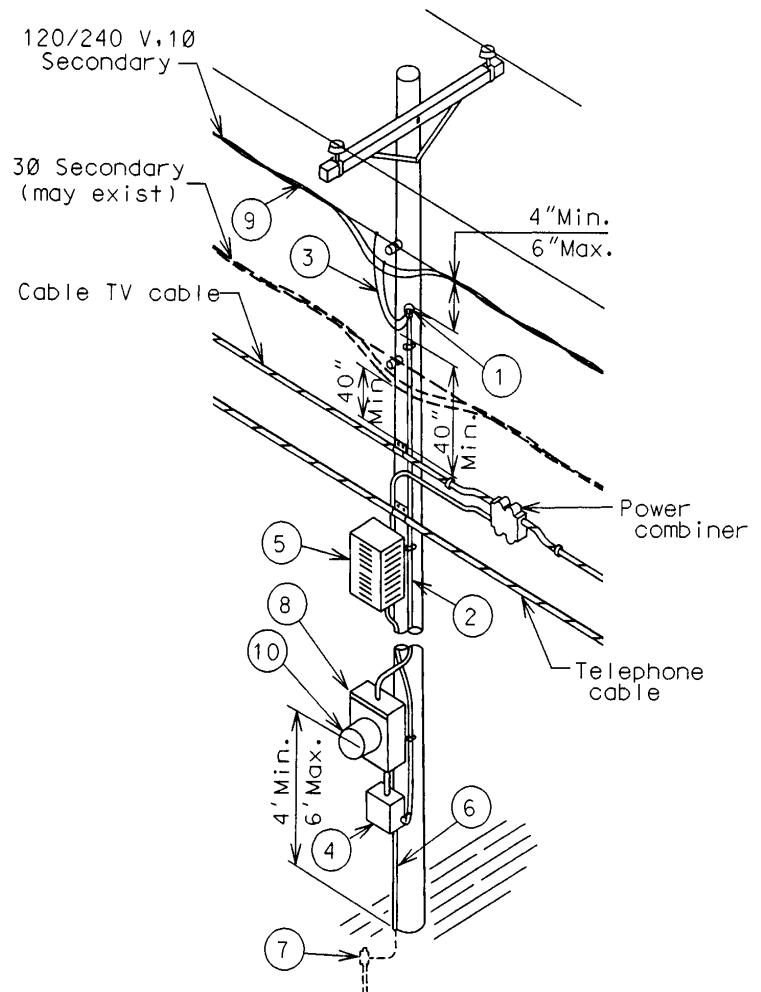

**SERVICE TO A TELEPHONE CO. POLE MOUNTED DRYER
1-PHASE, 120 VOLTS, 0-30 AMPERES**

Customer furnishes and installs:

1. Air dryer (see Note 1).
2. Weatherproof dead front, fuse or circuit breaker (see Note 2).
3. Service head, entrance conduit and minimum size #10 conductor (see Notes 3 & 4).
4. Company listed meter socket.
5. Air line covered with molding.
6. Alarm pair covered with molding.
7. Grounding electrode conductor covered with molding.
8. Grounding electrode(s) per applicable codes (see Sheet O-2).

Company furnishes and installs:

9. Service conductors and connectors from secondary to service entrance conductors.
10. Watthour meter.

Notes:

1. Unit may not be mounted on any pole on which there are risers, vertical supply conductors to aerial services, switch handles, traffic signals, capacitor banks or similar fixtures. Air line, alarm pair and service conduit are risers, and no more than 3 risers are permitted on a pole.
2. All installations must conform to the Wisconsin or Michigan State Electrical Code for clearances, climbing space, working space.
3. Where mounted on a pole on which a lighting fixture is installed, a clearance of 20" is required to an ungrounded fixture or 4" if fixture is grounded and bonded to the communication strand.
4. Non-metallic conduit, Schedule 80. If metallic conduit is used, it shall be covered with a non-metallic covering 40" above and 72" below any communications attachments.
5. Not to be served from a transformer equipped with neutral isolator.

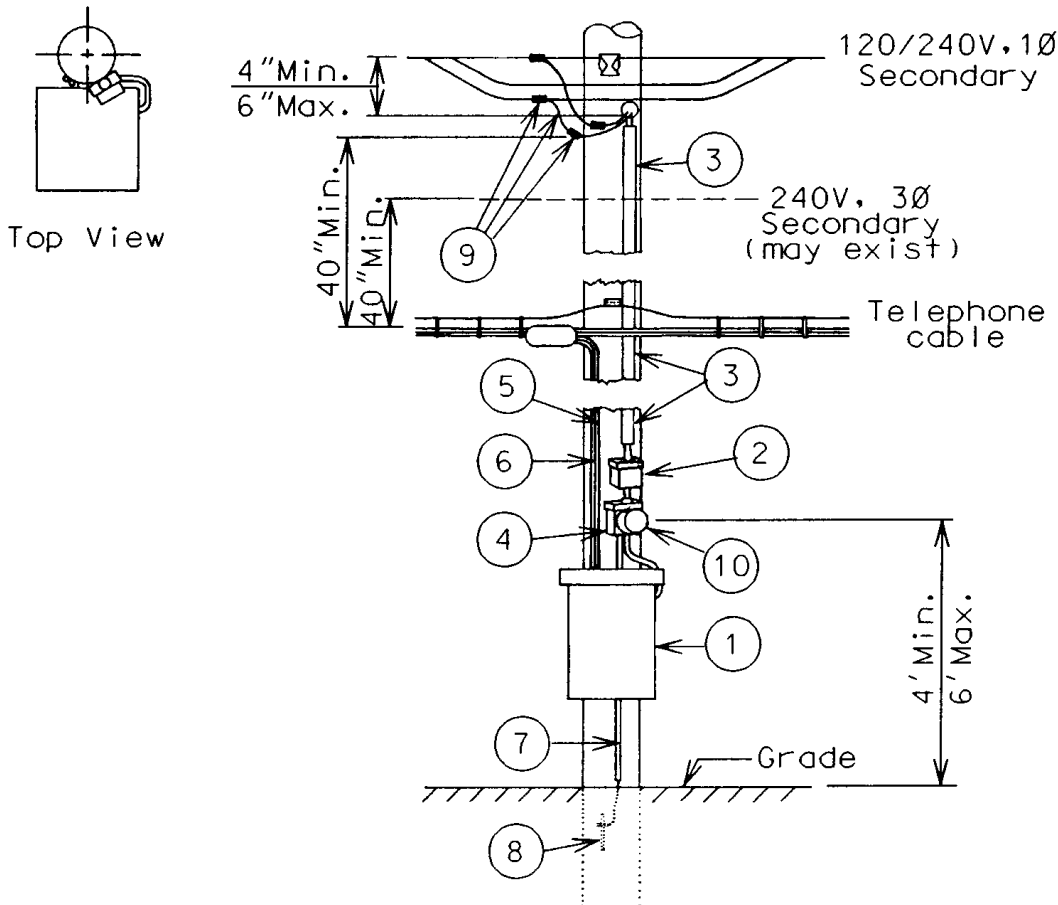

**SERVICE TERMINATION IN A MULTI-POSITION METER SOCKET
1-PHASE, 120/240 VOLTS, 0-200A PER METER, 2-6 METERS
OVERHEAD SERVICE**

Customer furnishes and installs:

1. Service entrance conduit (see Note 1).
2. Service entrance conductors (see Notes 1 and 2).
3. Metallic conduit shall be bonded.
4. Company listed 2 to 6 position meter socket (see D-3, D-4, or D-5).
5. Weather-tight hub.

Company furnishes and installs:

6. Watthour meter.
7. Service lateral (not pictured).

Notes:

1. Customer entrance conduit should exit socket as shown below. Alternative knockouts (dotted lines), out of the side, out of the back, or out of the center portion of the socket can be utilized instead as well. If the center section alternative location is used, only conductors from one meter socket shall enter it.
2. If the center alternative location is not utilized, the service entrance conductors shall exit directly below (bottom knockout or back knockout) or directly to the right or left of the corresponding meter socket.
3. Customer entrance conductors shall be routed out of the socket such that metered conductors from separate meters do not cross.
4. Each meter position shall be marked on the outside of the socket or by the breaker (if available) with the address of the unit served. If the marking is on the outside of the removable cover, it shall also be marked on the inside of the meter socket in a visible location. This marking shall also be placed on the corresponding distribution panel(s). The marking shall be a permanent label with 1/2" block letters and may consist of individual self-stick letters or numbers, suitable for the location so as to be considered permanent (see Note 7 on M-2).

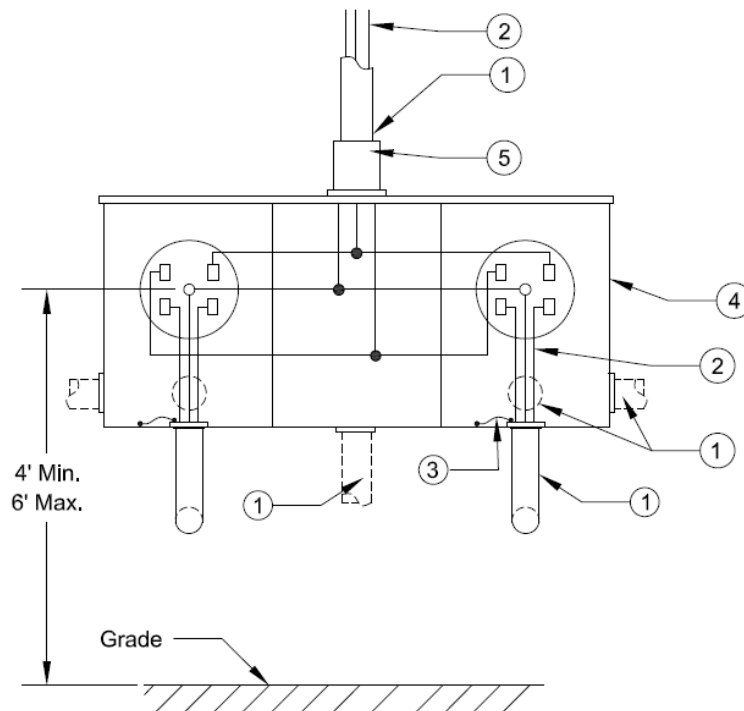

UNDERGROUND SERVICES – SECONDARY

General requirements for underground service	U-2
Reference	
Name of parts for underground service	U-3
Typical number and size of service lateral conduits installed	U-3
Conduit layouts.....	U-4
Service termination in a service assembly for mobile homes	
1 or 2 meters, 1Ø, 120/240 volt, 0-200A per meter.....	U-5
Service termination in a meter pedestal, direct buried lateral (0-320A)	
Free standing, 1 meter.....	U-6
Attached to a building	U-7
Service termination in a multi-position meter socket	
Direct buried lateral	U-8
Service termination in an outdoor meter socket	
Temporary service.....	U-9
Service termination in a transocket	
Freestanding & temporary service	U-10
Freestanding for farm services only	U-11
Outdoor concrete encased lateral	U-12
Outdoor direct buried or direct buried conduit lateral	U-13
Padmounted – bottom entry and exit.....	U-14
First floor installation, concrete encased lateral	U-15
First floor installation, direct buried lateral	U-16
Service termination in a termination compartment	
General information	U-17
All outdoor laterals.....	U-18
Above grade – bottom entry and exit.....	U-20
Free standing – bottom entry and exit	U-22
Padmounted – bottom entry and exit.....	U-24
Concrete encased lateral – multi-metered installations.....	U-25
Building without a basement – first floor installation – multi-metered installations	U-26
Concrete encased lateral – located below grade *conduit and manhole system only*	U-28
Free standing switchgear – located below grade – for areas served by conduit and cable only.....	U-29
Free standing switchgear – located on first floor or above	U-30
Communication towers	
Policy on services	U-31
Service termination in a free standing multi-position meter socket – direct buried lateral.....	U-32

GENERAL REQUIREMENTS FOR UNDERGROUND SERVICE

Space Requirements

1. The unobstructed space required in front of termination compartments, transockets, and metering equipment shall be as defined by the "Working Space About Electrical Equipment," Section 110.26 of the **National Electric Code** (as adopted by the states Michigan and Wisconsin). This unobstructed space shall extend from the floor, or ground, to a minimum height of 6'-6". For equipment higher than 6'-6", this space shall extend to the top of the equipment.

Service Laterals and Entrances

1. Service laterals are furnished and installed by the Company.
2. Service laterals will generally be terminated in a meter pedestal, transockets, or termination compartment. Customers shall obtain information from the Company relative to the proper location of service lateral and termination equipment. Such information will be furnished in writing upon request.
3. The preferred termination of service laterals is on the outside of a building (or structure). Service laterals that terminate inside of a building shall terminate immediately upon entering as shown in this manual. The raceway for service laterals under or through a building shall not extend longer than 8' after penetrating the outside wall. **This 8' rule is a We Energies 8' requirement in addition to the SPS 316 8' requirement.** NEC article 230.6, *Conductors Considered Outside the Building*, are not exempt from the We Energies 8' rule. Services that terminate in a mezzanine are allowed a maximum length of 14' measured from grade.
4. With Company approval, service laterals, generally 2000 Amp or larger, may be terminated in the customer's switchgear or on the customer's bus duct. This type of installation is further restricted by the following:
 - a. Customer shall provide all necessary plastic conduit encased in 3" of concrete for the extension of the cable within his building (see Note 3 above).
 - b. Customer shall obtain Company acceptance of the switchgear termination and C.T. compartment design. **A copy of the switchgear plans shall be submitted to the local We Energies job representative for acceptance.** The plans must show the general layout of the switchgear, the switchgear location within the building, and the specific details of the termination compartment and any C.T. compartment(s). Specific details such as compartment size, bus spacing and drilling dimensions, other clearances, bus and bus support configuration, barrier location, sealing provisions, and materials used are to be included.
5. Only meter mounting devices and termination equipment approved and listed in **Section D** of this manual are to be used. Additionally, all equipment must be listed by a nationally recognized testing laboratory, e.g. UL, installed, and used as per the listing and the manufacturer's instructions.
6. Where metallic rigid conduit or IMC is used for the service lateral conduit, the ends are to be threaded and threaded couplings, connectors, or locknuts are to be used. Slip type fittings shall not be used.
7. For outdoor service terminations with a direct burial lateral, the horizontal portion of the conduit shall extend through a minimum of 12" of undisturbed earth where practical, defined as follows:
 - a. Undisturbed earth: The area not excavated for the construction of the building (may be compacted fill).
 - b. Fill area: The area between the building wall and the undisturbed earth (may vary from a few inches to several feet or more).
8. Underground services shall require a minimum 6' wide path of clearance.
9. Refer to outlet location letter and/or signed sketches for services that may have concrete encased laterals.
10. Excess service entrance conductor slack is not allowed to be "lost" in the service entrance equipment.

Grounding

1. Grounding shall be in accordance with all applicable codes.
2. The grounding electrode conductor shall not be run through the meter pedestals, transockets, or termination compartment, unless a separate raceway is provided. **Raceway shall not be installed inside service equipment.** The grounding electrode conductor may terminate on the neutral bus of: the termination compartment for multi-metered installations provided it does not interfere with the installation of the service lateral conductors or a meter pedestal equipped with a main disconnect and listed as Service Equipment.
3. Ground rods and grounding electrode conductors shall not be located in front of meter pedestals or raceways.
4. Bonding to other systems(ex: communication) shall not be done on/within a metering enclosure unless a means of bonding intended for inter-system bonding is furnished as part of the metering enclosure (PSC 114.099(C)).

Metering

1. This section details the requirements for underground service lateral terminations and connections. Refer to the metering section of this manual for details of the metering requirements for each installation.

REFERENCE

NAME OF PARTS FOR UNDERGROUND SERVICE

Customer furnishes and installs:

- A - Meter pedestal
- B - Service entrance conduit and conductors
- C - Distribution panel, main fuse/disconnect
- D - Transocket
- E - Transformer rated meter socket
- F - Wiring trough (1600 Amp maximum)
- G - Termination compartment, either wire or bus connected type.
- H - Metering or main disconnect/fuse, wire connected for use with wire type termination compartment only.

Customer furnishes and installs:

- I - Metering equipment, bus connected for use with bus connection type termination compartment only and of same manufacturer.
- J - Service lateral conduit

Company furnishes and installs:

- K - Underground service lateral
- L - Watthour meter

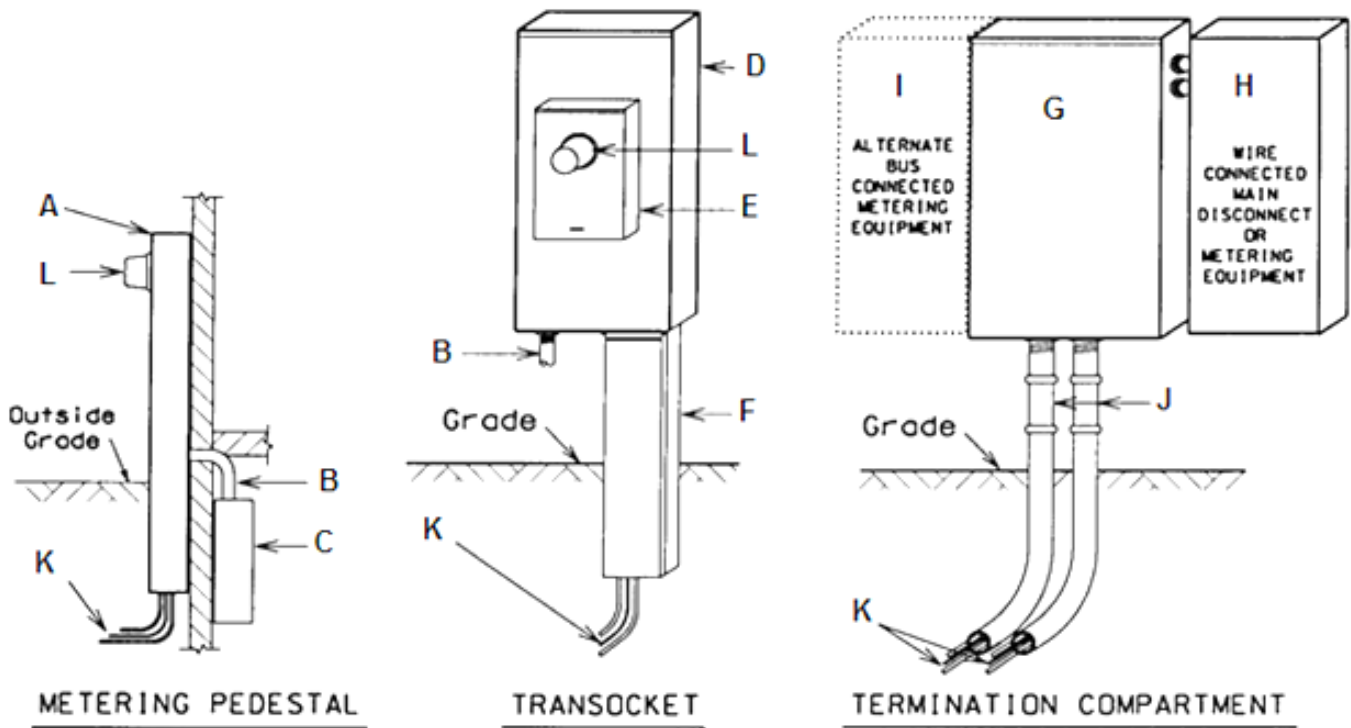

TYPICAL NUMBER AND SIZE OF SERVICE LATERAL CONDUITS INSTALLED

Service Size	Number of Conduits	Size of Conduits	Number of Conduit Sweeps	Size of Conduit Sweeps (radius)
400A	1	4"	1	36"
600A	2*	4"	2	36"
800A	2	4"	2	36"
1200A	3	4"	3	36"
1600A	4	4"	4	36"
2000A	6	4"	6	36"
3000A	8	4"	8	36"
4000A	10	4"	10	36"

Note: See page U-4 for conduit layouts.

***If 1-750 is used then only one conduit is needed**

REFERENCE

CONDUIT LAYOUTS

For indoor gear, customer furnishes and installs:

1. Service lateral conduit.
2. Steel reinforcing rods, 5/8" x 6' (epoxy coated re-bar).
3. Conduit spacers.
4. Continuous concrete envelope with a minimum of 3" of concrete on all sides.

Notes:

1. The grounding electrode conductor shall not be run through the meter pedestals, transockets, or termination compartment, unless a separate raceway is provided.
2. A concrete encased service lateral is provided for 3000A and larger services, areas fed by the conduit and manhole system, and as needed for mechanical protection or ampacity concerns.
3. For non-concrete encased service laterals, the company's conduit service lateral will be installed in the same configurations as shown.

Conduit Details for 400 – 1600 Amperes

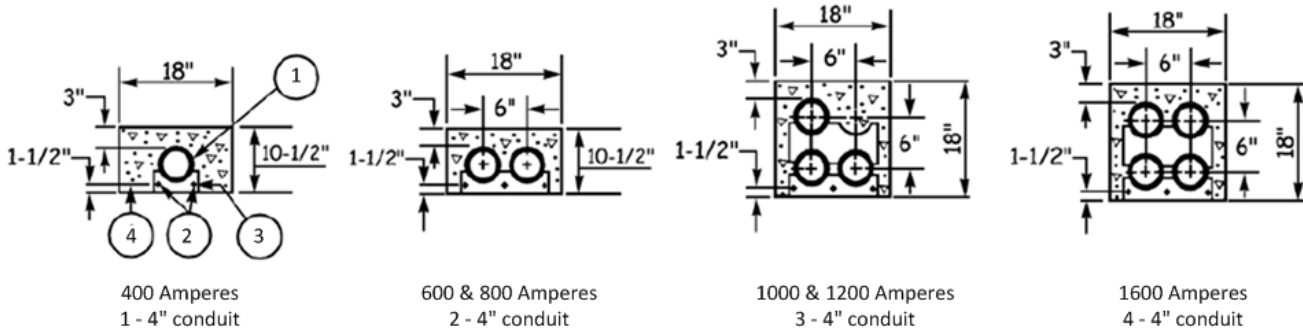

Conduit Details for 2000 – 4000 Amperes

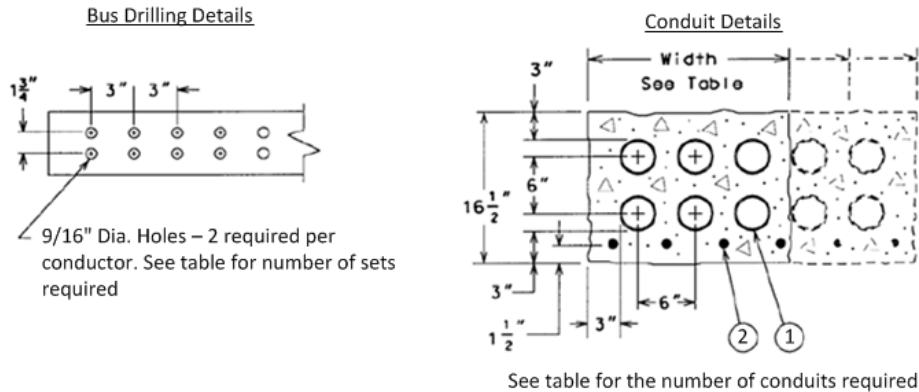

Switchgear Requirements 2000, 3000, and 4000 Amperes				
Switchgear Amperage	Minimum Width of Termination Compartment	Sets of Holes Required	Minimum Number of Ducts	Width of Conduit Package
2000	24 Inches	6	6	24 Inches
3000	30 Inches	8	8	30 Inches
4000	36 Inches	10	10	36 Inches

Note: The dimensions shown above are minimums and should not be used for design purposes. For actual dimensions contact the switchgear manufacturer.

Note: For switchgear, the conduit shall be installed so the duct package width is parallel with the bus.

SERVICE TERMINATION IN A SERVICE ASSEMBLY FOR MOBILE HOMES

1 OR 2 METERS, 1Ø, 120/240 VOLT, 0-200A PER METER

Customer furnishes and installs:

1. Company listed mobile home metering pedestal (see D-11).
2. Company listed pedestal supporting stake bolted to the pedestal (see D-9) or equivalent (see Note 1).
3. Grounding electrode conductor in non-metallic conduit and grounding electrode(s) per applicable codes (see U-2).

Company furnishes and installs:

4. Watthour meter.
5. Service lateral (radial feed, loop through installation)

Notes:

1. A 1-5/8" x 1-5/8" galvanized steel framing channel 80" long or a galvanized steel support or equal strength.
2. Article 550 of the *National Electric Code* covers the special requirements for mobile homes. A few of the requirements are listed below. See the NEC for a complete listing of the requirements.
 - Mobile home service equipment must have a means for providing service to an auxiliary building or electrical equipment located outside the mobile home by a fixed wiring means.
 - Additional 120 Volt, 15 or 20 Amp GFCI protected receptacles are permitted for equipment located outside of the mobile home.
 - The service or disconnecting means must be within sight of and not more than 30 feet from an exterior wall of the mobile home.
 - All wiring must be installed as per the NEC, State, and Local ordinances.

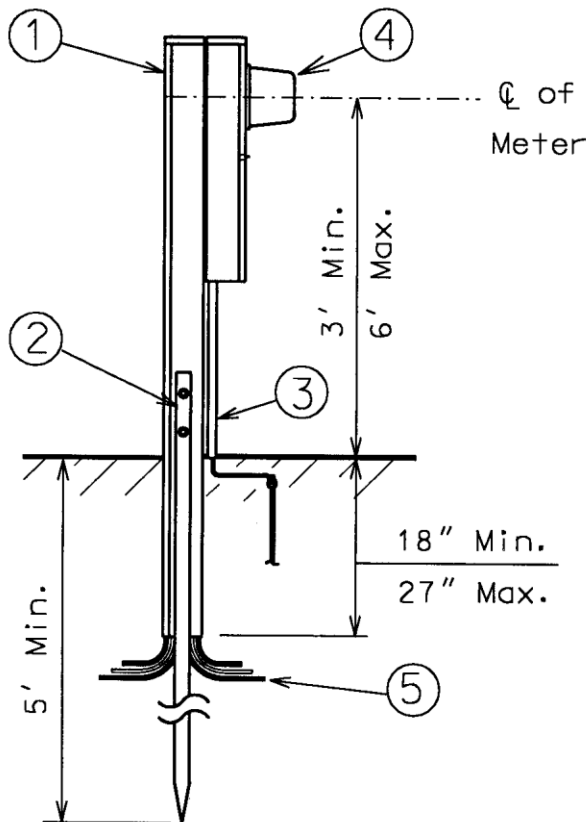

SIDE VIEW of SINGLE METER UNIT

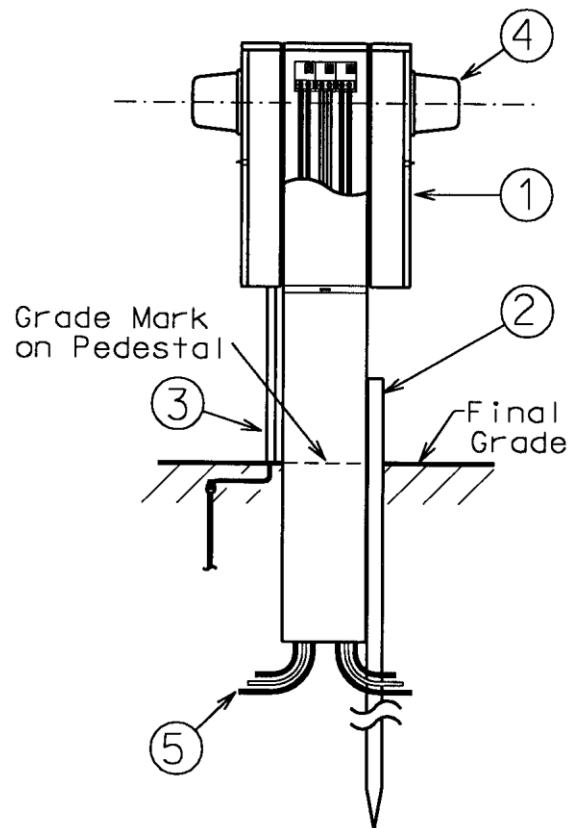

SIDE VIEW OF DOUBLE METER UNIT SHOWING SERVICE LATERAL TERMINATIONS

SERVICE TERMINATION IN A METER PEDESTAL, DIRECT BURIED LATERAL (0-320A)

FREE STANDING, 1 METER NOT TO BE USED FOR MOBILE HOMES

Customer furnishes and installs:

1. Company listed meter pedestal (see Notes 1).
2. Company listed supporting stake or concrete footing (.75 cubic feet minimum) (see Notes 2 & 3 and D-9)
3. Service entrance conductors (not shown, see Note 4).
4. Service entrance conduit.
5. Ground conductor in non-metallic conduit, installed only when the pedestal has a main disconnect.
6. Grounding electrode(s) per applicable codes (see U-2).
7. Accessory foot for concrete foundations.

Company furnishes and installs:

8. Service lateral.
9. Watthour meter.

Notes:

1. Unit shall have a main service switch and fuse, or circuit breaker, either integral or attached to the pedestal.
2. Pedestal shall be set in firmly compacted soil up to the grade line of the pedestal.
3. A 1-5/8" x 1-5/8" galvanized steel framing channel 80" long or a galvanized steel support of equivalent strength.
4. Service entrance conductors shall exit the pedestal below the lowest live part and above grade.

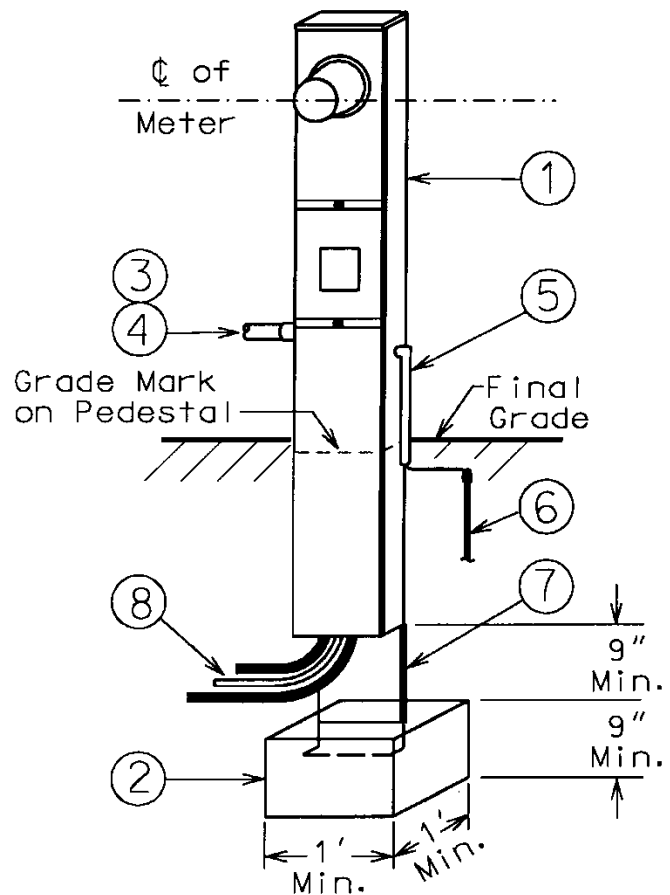
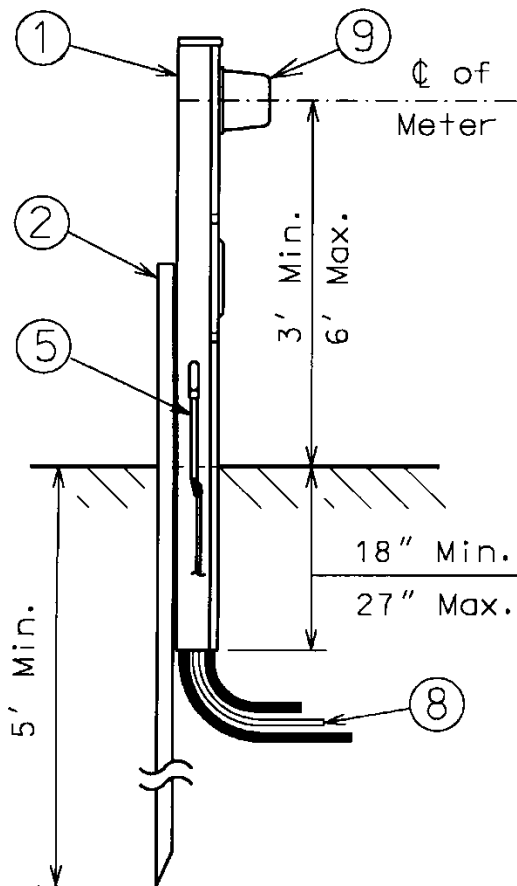

SERVICE TERMINATION IN A METER PEDESTAL, DIRECT BURIED LATERAL (0-320A) ATTACHED TO A BUILDING

Customer furnishes and installs:

1. Company listed meter pedestal (see Notes 1 & 2).
2. Service entrance conduit.
3. Service entrance conductors (not shown, see Note 3).

Company furnishes and provides:

4. Service lateral.
5. Watthour meter.

Notes:

1. Pedestal shall set in firmly compacted soil up to the grade line of the pedestal.
2. The customer shall be responsible for firmly securing the pedestal to the building.
3. Service entrance conductors shall exit the pedestal below the lowest live part and above grade.
4. An allowance for the building wall, when the pedestal is mounted to the foundation, must be present.
5. When a two position meter pedestal is installed, the positions must be labeled (see Note 7 on M-2).

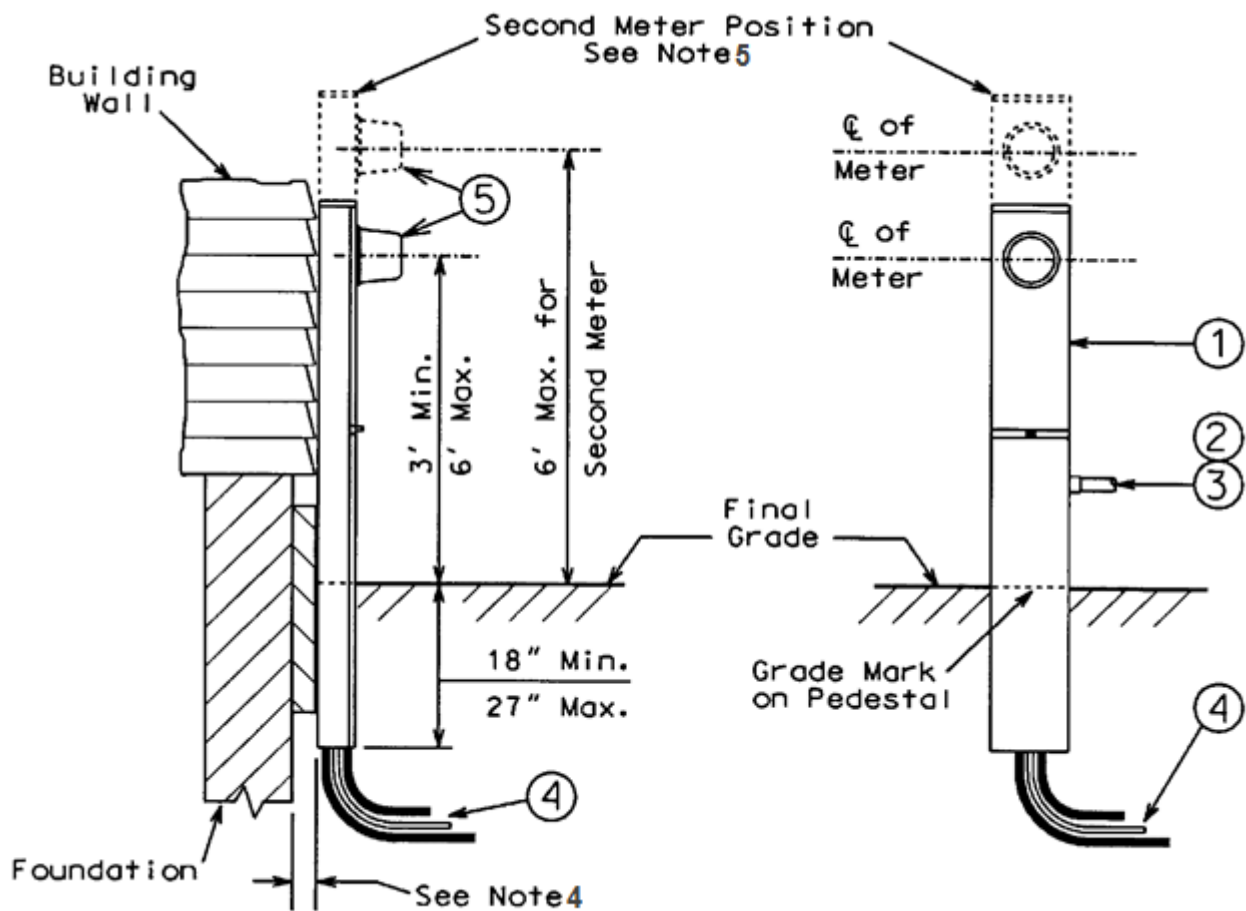

SERVICE TERMINATION IN A MULTI-POSITION METER SOCKET (1Ø, 120/240 VOLTS, 0-400A BUS, 0-200A PER METER, 2-6 METERS)

DIRECT BURIED LATERAL

Customer furnishes and installs:

1. Service entrance conduit.
2. Service entrance conductors.
3. Metallic conduit shall be bonded.
4. Company listed 2 to 6 position meter socket (see all Notes below and D-7, D-8, or D-9).
5. Service lateral wiring raceway.

Company furnishes and installs:

6. Service lateral.
7. Watthour meters (not shown).

Notes:

1. The company will provide lugs for terminating incoming service lateral for all sockets rated 600 Amps or more.
2. Separate cable compartments provided on some meter sockets are for the Company's service lateral cable only.
3. Each meter position shall be marked on the outside of the socket or by the breaker (if available) with the address of the unit served. If the marking is on the outside of the removable cover, it shall also be marked on the inside of the meter socket in a visible location. This marking shall also be placed on the corresponding distribution panel(s). The marking shall be a permanent label with 1/2" block letters and may consist of individual self-stick letters or numbers, suitable for the location so as to be considered permanent (see Note 7 on M-2).

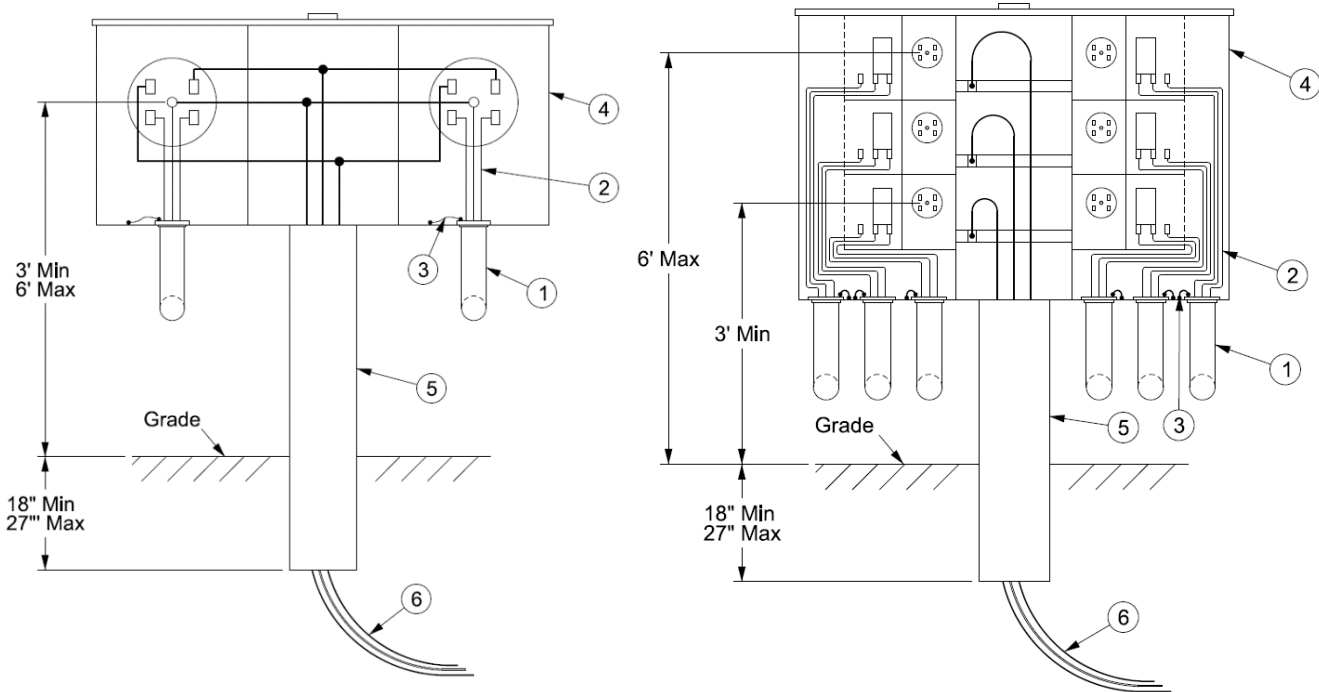

SERVICE TERMINATION IN AN OUTDOOR METER SOCKET

TEMPORARY SERVICE

1Ø, 120/240 VOLTS, 0-200A

1Ø, 120/208 VOLTS, 0-100A

Customer furnishes and installs:

1. Treated 4" x 4" wood post or equivalent (see Note 1).
2. Painted 3/4" weatherproof plywood to extend a minimum of 1" beyond the meter socket on all 4 sides.
3. Company listed 200A meter socket (D-7).
4. Metallic conduit shall be bonded.
5. Service entrance conductors.
6. Service entrance conduit.
7. Weatherproof disconnecting means (see Note 2).
8. Ground conductor in conduit.
9. Grounding electrode(s) per applicable codes (see U-2).
10. Service lateral conduit (see Note 3).
11. Split ring type conduit supports or galvanized steel 2-hole conduit straps.
12. 2" 90° elbow (see Note 3).

12. 2" 90° elbow (see Note 3).

Company furnishes and installs:

13. Service lateral.
14. Watthour meter (not shown).

Notes:

1. The temporary service assembly shall be located 6' from the Company service pedestal or padmounted transformer.
2. Consult the local Company office for alternate locations for mounting the disconnect.
3. 2" galvanized rigid, galvanized intermediate, or rigid non-metallic sch. 80 PVC conduit per NEMA standard TC-2.
4. For larger C.T. rated temporary services, see freestanding & temporary transockets, U-10.

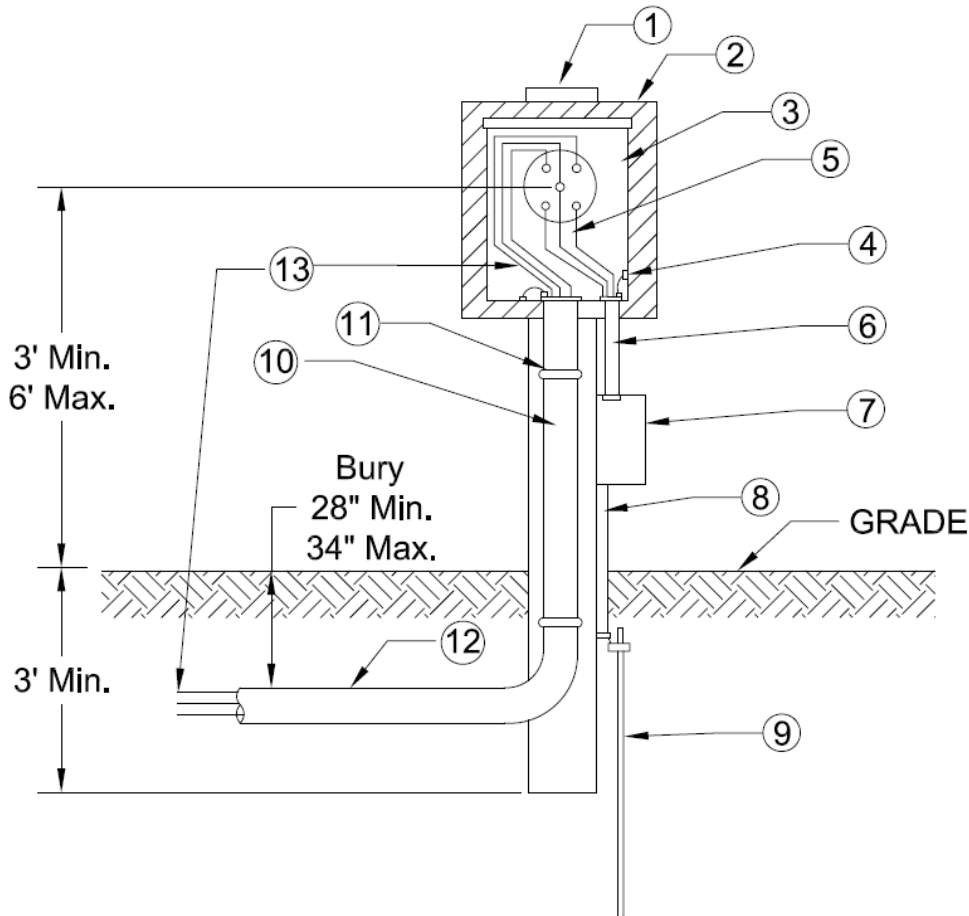

SERVICE TERMINATION IN A TRANSOCKET

FREESTANDING & TEMPORARY SERVICE

1Ø, 120/240 VOLTS, 400-800A

ALL 3Ø VOLTAGES, 400-3000A

Obtain accept for 1Ø installations larger than 400A from the Company

Customer furnishes and installs:

1. Company listed transocket (see M-17 & D-15).
2. Company listed transformer rated meter socket, supplied with transockets (see D-17).
3. Service lateral conduit (Raceway preferred see Notes 1, 2, & 3).
4. 4" galvanized rigid or IMC 90° elbow with 24" radius.
5. Insulated conduit bushing (see Note 4).
6. Service entrance conduit.
7. Galvanized steel framing channel, 1-5/8" x 1-5/8" x 12 Ga.
8. Two conduit supports solidly attached to frame (above grade).
9. 3" galvanized rigid with galvanized end cap (see Note 5).
10. Concrete footing (12" min. hole size).

Company furnishes and installs:

11. Service lateral with compression lug terminations (600A +).
12. Watthour meter, current transformers, & associated meter wiring.

Notes:

1. Galvanized rigid or galvanized intermediate conduit with threaded ends and threaded fittings at the transocket are required. Metallic conduit shall be bonded. Reference page U-3 for the proper number and size of the conduits and U-4 for conduit details. Contact the We Energies job representative for approval.
2. Conduits to be grouped at end furthest from the termination compartment to allow for service lateral bending.
3. For 400-1600 Amp services, a Company listed cable raceway is preferred (shown as dashed line below). The cable raceway can be used in place of Item 3 above (see D-16).
4. Service lateral conduit shall have a temporary waterproof end cap to prevent the accumulation of water, ice, and other foreign matter from inside the conduit.
5. As an alternative to Item 9 above, 4" x 4" x 3/8" galvanized steel angle may be used.
6. For concrete encased service lateral, refer to U-12, U-20/21, and U-22/23.
7. Temporary services may also be constructed out of wood, refer to U-11.

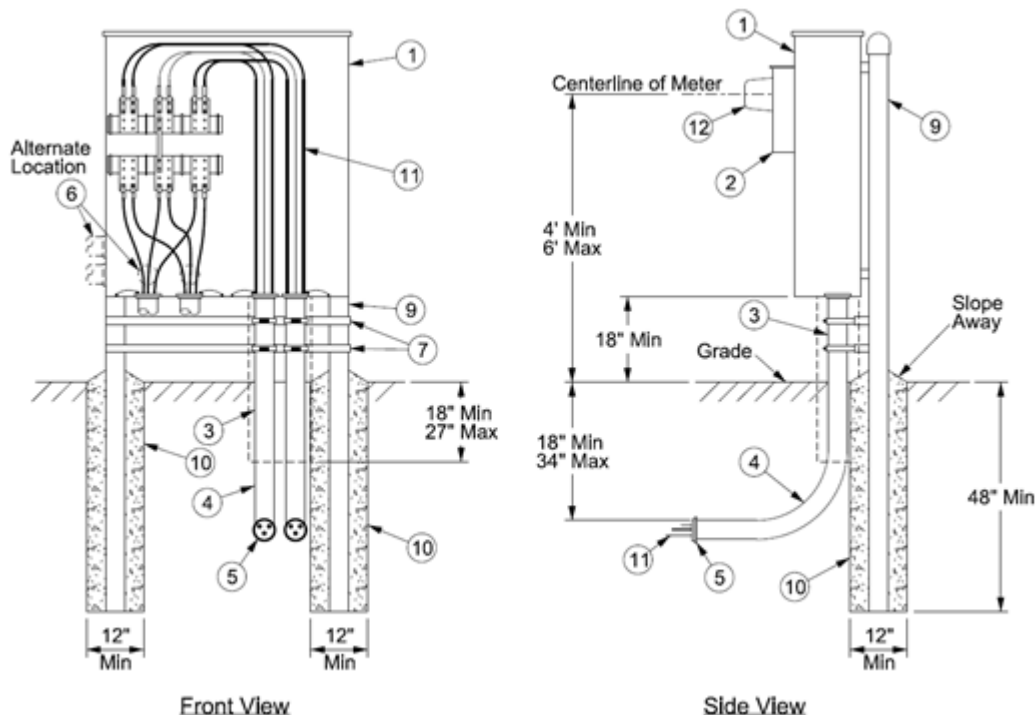

Single phase, 3-wire transocket shown.

SERVICE TERMINATION IN A TRANSOCKET

FREESTANDING FOR FARM SERVICES ONLY

1Ø, 120/240 VOLTS, 400-800A

Obtain acceptance for 1Ø installations larger than 400A from the Company

Freestanding Wood Frame may be used for Temporary Services, refer to Page U-10 for service size

Customer furnishes and installs:

1. Company listed transocket (see M-17 & D-15).
2. Company listed transformer rated meter socket, supplied with transocket (see D-17).
3. Service lateral conduit (see Notes 1, 2, & 3).
4. 4" galvanized rigid or IMC 90° elbow with 24" radius.
5. Insulated conduit bushing (see Note 4).
6. Service entrance conduit.
7. Galvanized steel framing channel, 1-5/8" x 1-5/8" x 12 Ga.
8. Two conduit supports solidly attached to frame (above grade).
9. Post, 6" x 6", pressure treated for ground contact (preservative retention of .60 # per cu. ft.)
10. Wood, 2X, pressure treated for above ground use (preservative retention of .40 # per cu. ft.)
11. Concrete footing (12" min. hole size).

Company installs and furnishes:

12. Service lateral with compression lug terminations (600A +).
13. Watthour meter, current transformers, & associated meter wiring.

Notes:

1. Galvanized rigid or galvanized intermediate conduit with threaded ends and threaded fittings at the transocket are required. Metallic conduit shall be bonded. Reference page U-3 for the proper number and size of the conduits and U-4 for conduit details. Contact the We Energies job representative for approval.
2. Conduit to be group at end furthest from the termination compartment to allow for service lateral bending
3. For 1Ø 400 – 800A services, a Company listed cable raceway is preferred. The cable raceway can be used in place of Item 3 above (see D-16 for approved raceways). Raceways shall extend 18" to 27" below final grade.
4. Service lateral conduit shall have a temporary waterproof end cap to prevent the accumulation of water, ice, and other foreign matter from inside the conduit.
5. Plywood, Particleboard, or OSB are not acceptable for use with this structure. Only 2X shall be used.

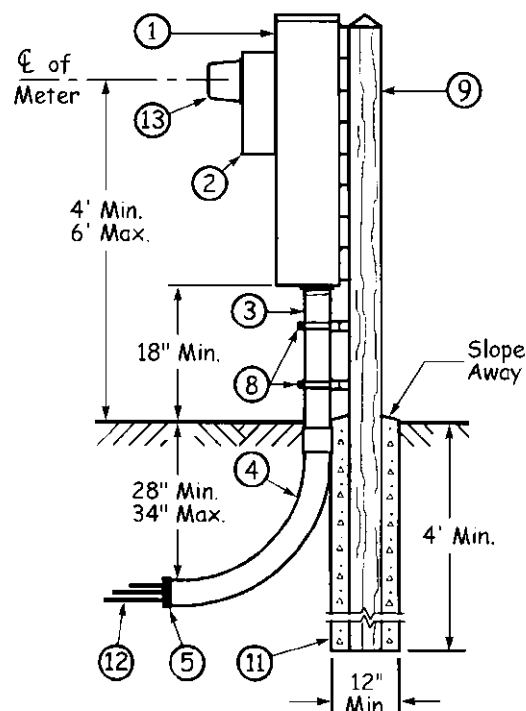
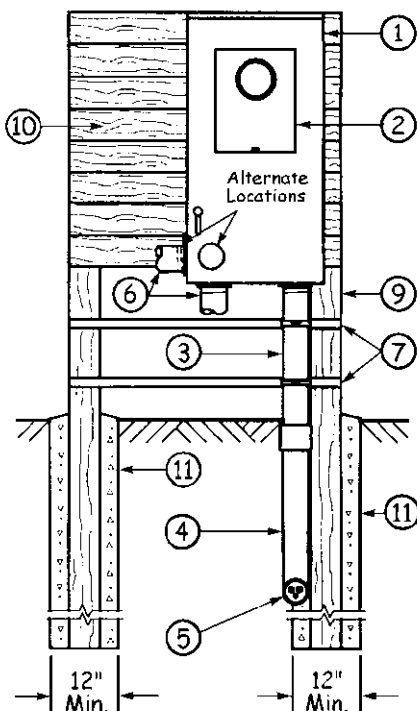

SERVICE TERMINATION IN A TRANSOCKET

OUTDOOR DIRECT BURIED OR DIRECT BURIED CONDUIT LATERAL

1Ø, 120/240 VOLTS, 400-800A

ALL 3Ø VOLTAGES, 400-2000A

Obtain acceptance for 1Ø installations larger than 400A from the Company

Customer furnishes and installs:

1. Company listed transocket (see M-17, D-15 & Note 1).
2. Company listed transformer rated meter socket, supplied with transocket (see D-17).
3. Service entrance conduit and conductors.
4. Metallic conduit shall be bonded.
5. Raceway, preferred, 1600A Maximum (see D-16).
6. Service lateral conduit (see Notes 2 & 3).
7. Two conduit supports solidly attached to building (above grade).
8. Solid bar.

Company furnishes and installs:

9. Service lateral with compression lug terminations (600A +).
10. Watthour meter, current transformers, & associated meter wiring.

Notes:

1. The cable trough compartment (for 400-1200A services) is for the Company's service lateral cables only. This compartment may be on the left side, contact your manufacturer or distributor.
2. Service lateral conduit shall have a temporary waterproof end cap when installed to prevent the accumulation of water, ice, and any other foreign material inside the conduit.
3. Galvanized rigid or galvanized intermediate conduit with threaded ends and threaded fittings at the transocket are required. Reference page U-3 for the proper number and size of the conduits and U-4 for conduit details. A Company listed cable raceway is the preferred method of installation. The cable raceway can be used in place of Item 4 above (see D-16 for approved raceways). Raceways shall extend 18" to 27" below final grade. Contact the We Energies job representative for approval.
4. Conduits to be grouped at the end furthest from the termination compartment to allow for service lateral bending (see Note 1).

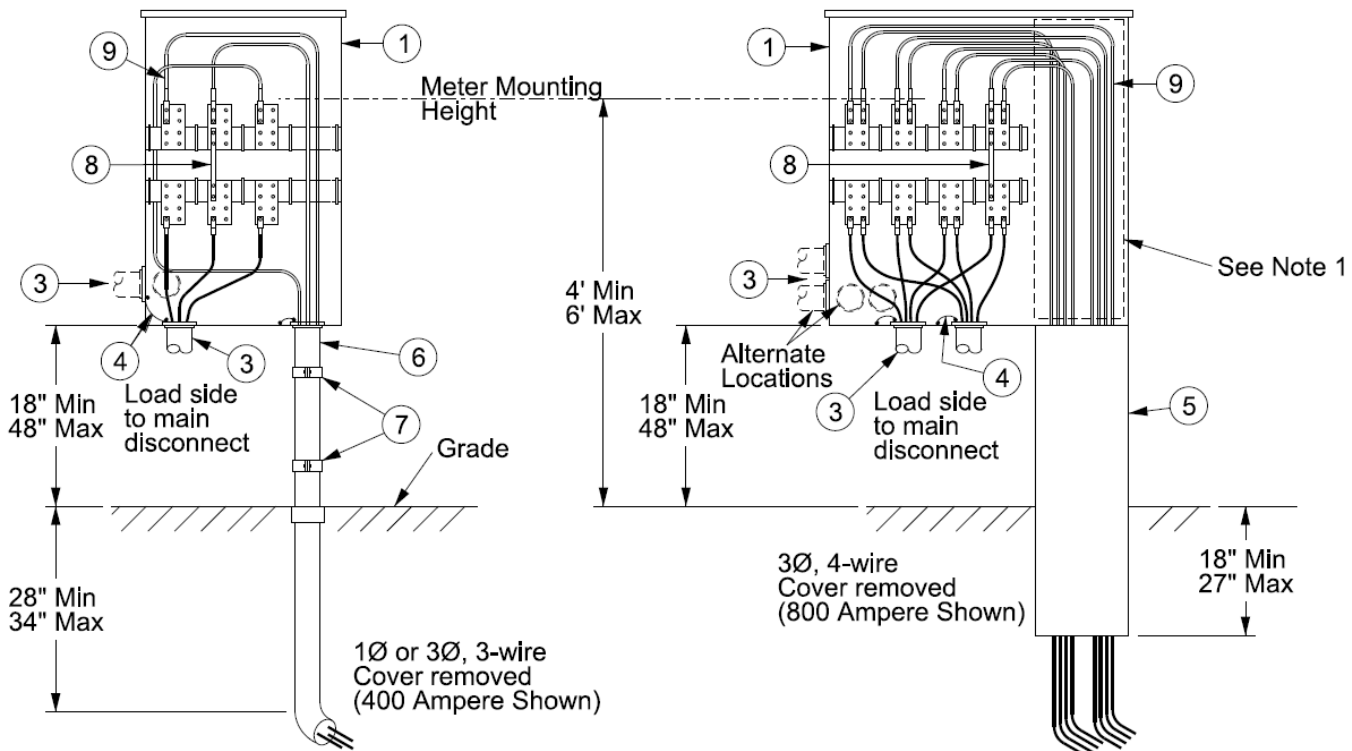

SERVICE TERMINATION IN A TRANSOCKET

FIRST FLOOR INSTALLATION, CONCRETE ENCASED LATERAL

1Ø, 120/240 VOLTS, 400-800A

ALL 3Ø VOLTAGES, 400-3000A

Obtain acceptance from the Company

Customer furnishes and installs:

1. Company listed transocket (see M-17, D-15, & Note 1).
2. Company listed transformer rated meter socket, supplied with transocket (see D-17).
3. Service lateral conduit (see Note 2).
4. Continuous concrete envelope with 3" of concrete on all sides (see Note 2).
5. 4" I.D. 90° bend with 36" minimum radius (see Note 2).
6. Steel reinforcing rods, 5/8" x 2'.
7. Insulated bushing & temporary watertight end cap.
8. Solid bar.

Company furnishes and installs:

9. Service lateral with compression terminations (600A +), conduit, coupling, & concrete envelope.
10. Watthour meter, current transformers, & associated meter wiring.

Notes:

1. The cable trough compartment (for 400-1200A services) is for the Company's service lateral cables only. This compartment may be on the left side, contact your manufacturer or distributor.
2. Galvanized rigid or galvanized intermediate conduit with threaded ends, or rigid nonmetallic schedule 40 PVC is acceptable. Reference page U-3 for the proper number and size of the conduits required and U-4 for conduit details. Contact the We Energies job representative for approval.
3. The We Energies 8' rule applies to all indoor service installations. See Note 3 on U-2 for details.

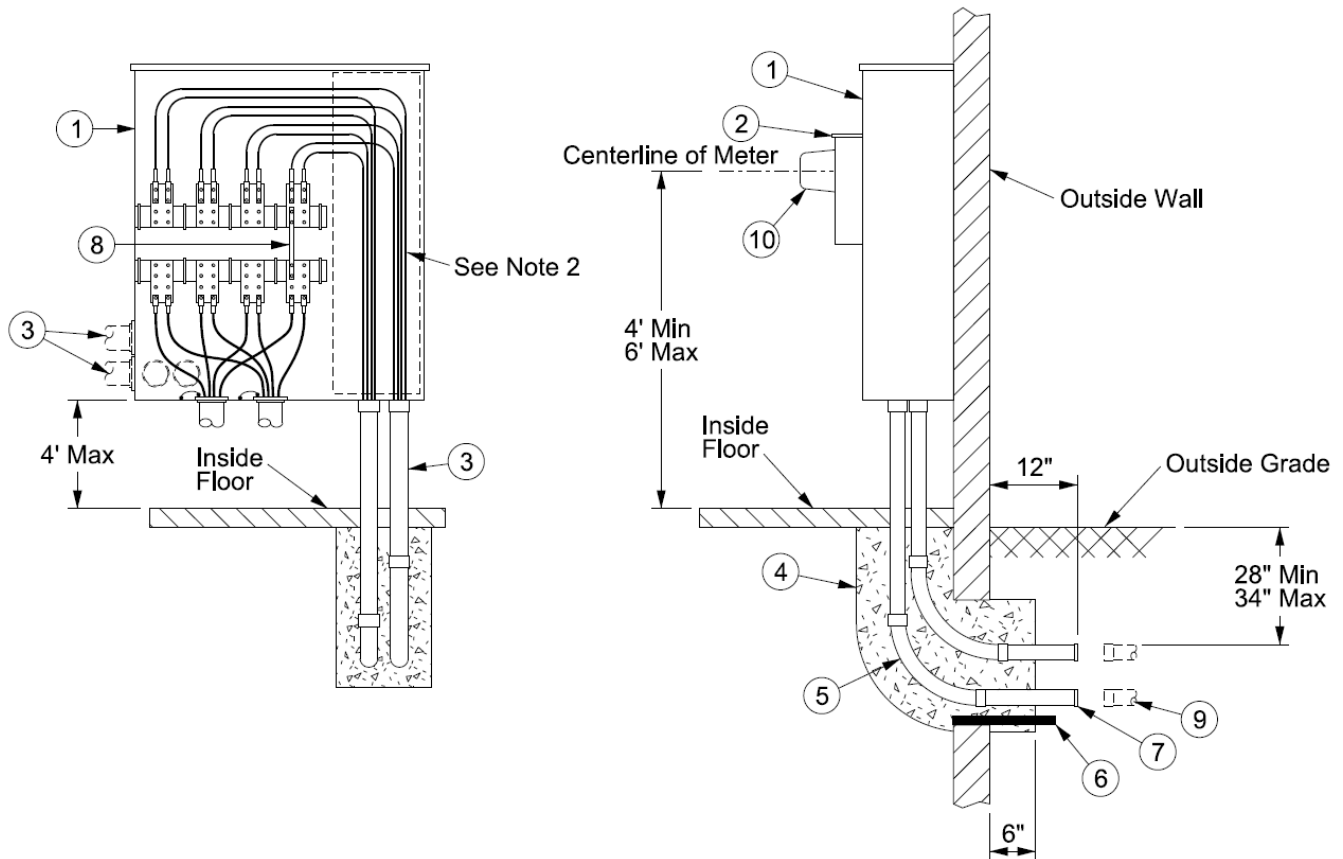

SERVICE TERMINATION IN A TRANSOCKET

FIRST FLOOR INSTALLATION, DIRECT BURIED LATERAL

1Ø, 120/240 VOLTS, 400-800A

ALL 3Ø VOLTAGES, 400-2000A

Obtain acceptance from the Company

Customer furnishes and installs:

1. Company listed transocket (see M-17, D-15, & Note 1).
2. Company listed transformer rated meter socket, supplied with transocket (see D-17).
3. Service lateral conduit (see Note 2).
4. Continuous concrete envelope with 3" of concrete on all sides (see Note 2).
5. 4" I.D. 90° bend with 36" minimum radius (see Note 2).
6. Insulated bushing & temporary watertight end cap.

Company furnishes and installs:

7. Watthour meter, current transformers, & associated meter wiring.
8. Service lateral with compression lug terminations (600A +) (not shown).

Notes:

1. The cable trough compartment (for 400-1200A services) is for the Company's service lateral cables only. This compartment may be on the left side, contact your manufacturer or distributor.
2. Galvanized rigid or galvanized intermediate conduit with threaded ends, or rigid nonmetallic schedule 40 PVC is acceptable. Reference page U-3 for the proper number and size of the conduits required and U-4 for conduit details. Contact the We Energies job representative for approval.
3. The We Energies 8' rule applies to all indoor service installations. See Note 3 on U-2 for details.

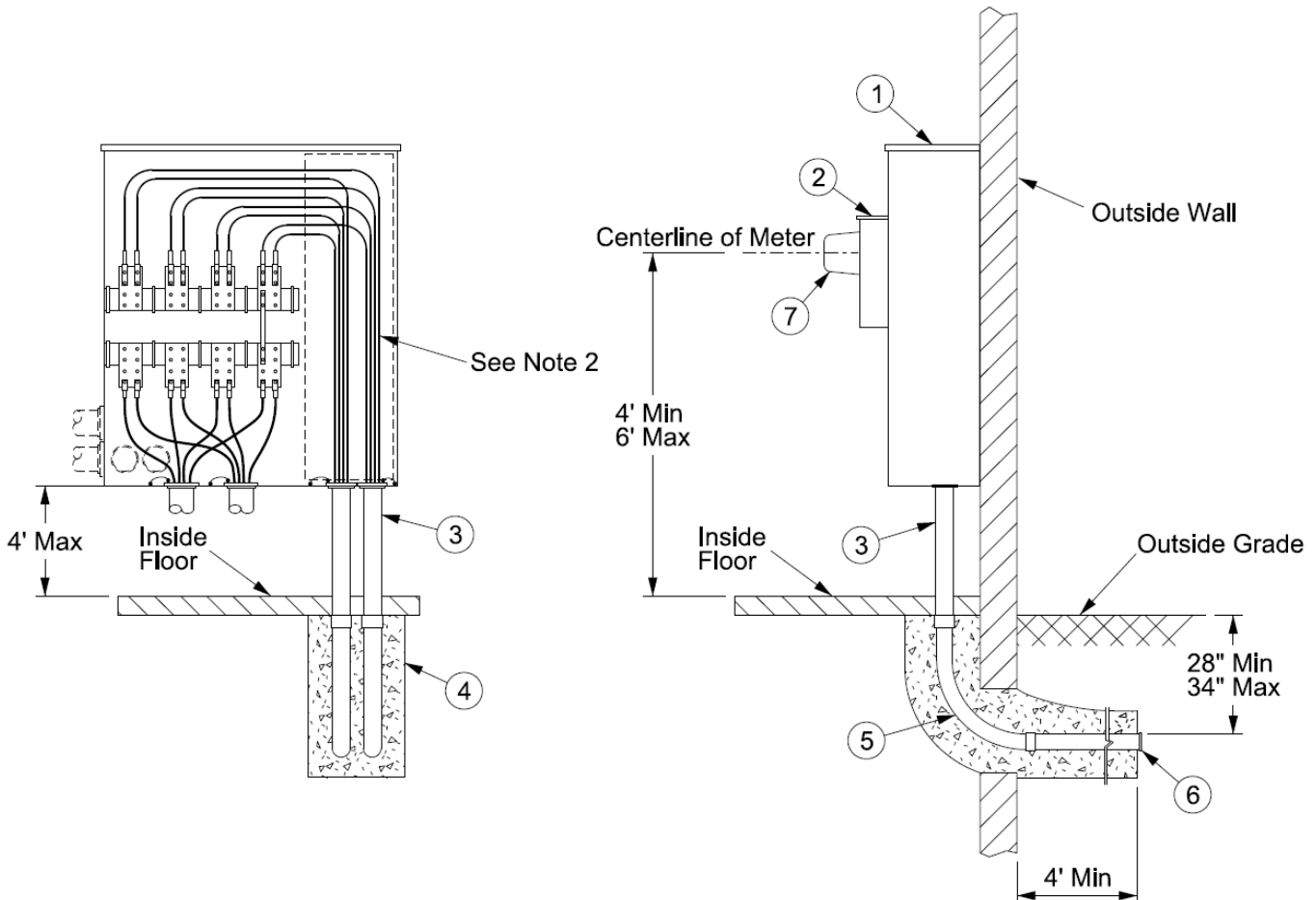

SERVICE TERMINATION IN A TERMINATION COMPARTMENT

GENERAL INFORMATION

Different manufacturers offer bottom entry, bottom exit termination compartments with different termination styles.

- a. Style A: Terminations run perpendicular to the face of the enclosure. The customer uses the rear portion of the terminations and conduits; the front portion of the terminations and conduits shall be reserved for the Company. The drawing below shows an example (with door removed), with the **customer** portion of the conduits and terminations outlined in yellow.

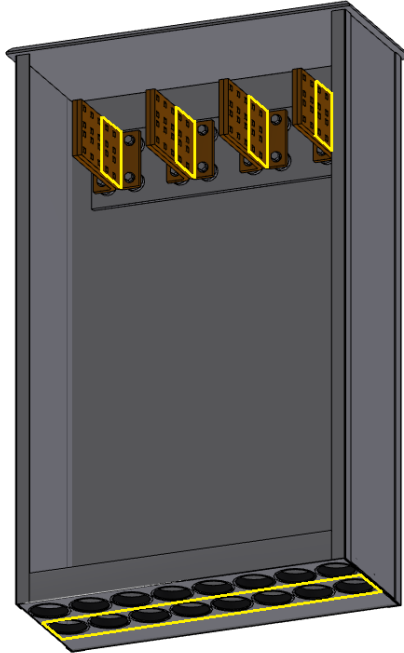

- b. Style B: Terminations run parallel to the face of the enclosure. The customer uses only one side of the terminations and conduits; the company uses the other. Follow the documentation provided by the Company to determine which side to use. The drawing below shows an example (with door removed), with the **customer** portion of the conduits and terminations outlined in yellow (customer designated left side shown).

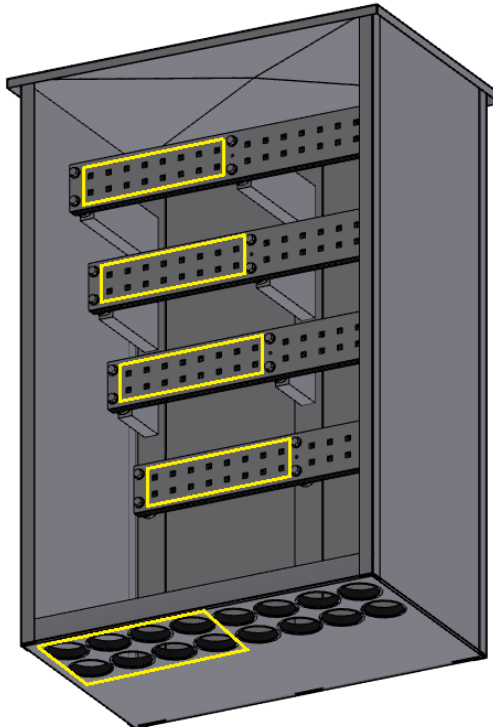

SERVICE TERMINATION IN A TERMINATION COMPARTMENT

ALL OUTDOOR LATERALS ALL 1Ø VOLTAGES, 400-800A ALL 3Ø VOLTAGES, 400-3000A

Obtain acceptance for 1Ø installations larger than 400A from the Company

Customer furnishes and installs:

1. Company listed termination compartment (see Note 1 & D-18).
2. Raceway, 400-1600A max (see Note 2 & D-16).
3. Service lateral conduit, 400-3000A (see Note 3).
4. Conduit supports.
5. Service entrance conduit (see Note 4).
6. Service entrance conductors (see Note 5).
7. Bonding. Metallic conduit shall be bonded.
8. 90° metallic elbow (see Note 6).
9. Insulated conduit bushing.

Company furnishes and installs:

10. Service lateral with compression lug terminations (600A +).
11. Conduit package.

Notes:

1. The termination compartment may be bonded to the neutral termination pad.
2. For either direct buried or concrete encased services 1600A or less, the raceway is preferred (see D-16 for approved raceways). For direct buried service laterals, raceways shall extend 18" to 27" below final grade. For concrete encased service laterals, raceways shall extend 3" to 6" below final grade. If the raceway cannot be used, such as where the termination compartment is located in a paved area, conduit may be used (both shown on next page). Consult We Energies job representative for approval and number of conduits required.
3. Galvanized rigid or galvanized intermediate conduit with threaded ends and threaded fittings at the termination compartment are required.. For concrete encased laterals, the lower ends are not required to be threaded. Conduits are to be located on 6" centers and extend to grade level. Reference page U-3 for the proper number and size of the conduits and U-4 for conduit details. Contact the We Energies job representative for approval.
4. If the service entrance conduits are located above the termination pads, watertight hubs or sealing locknuts are required. When the service entrance conduit enters cabinet at the top, watertight hubs are required.
5. The customer's service entrance conductors shall leave the termination compartment as a maximum of two circuits regardless of the number of conductors per phase.

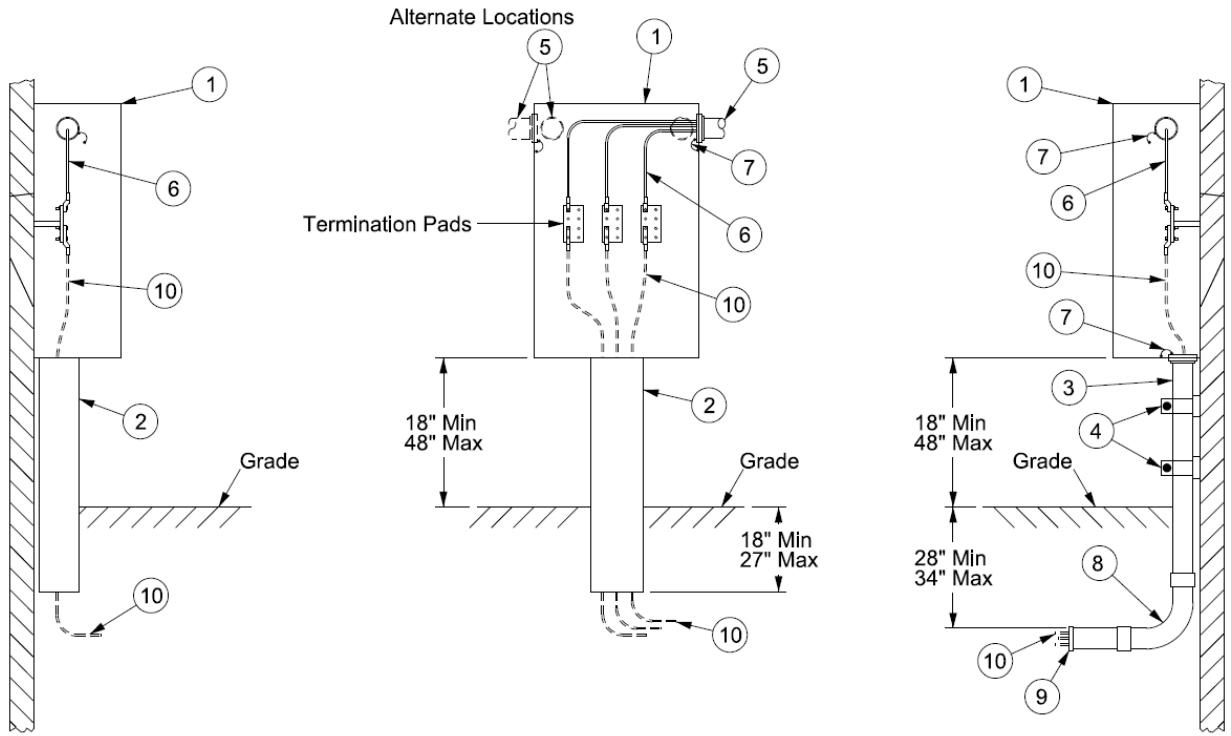

Side View Wireway

Front View Wireway

Side View conduit installation

WITH SERVICE LATERAL DIRECT BURIED IN EARTH

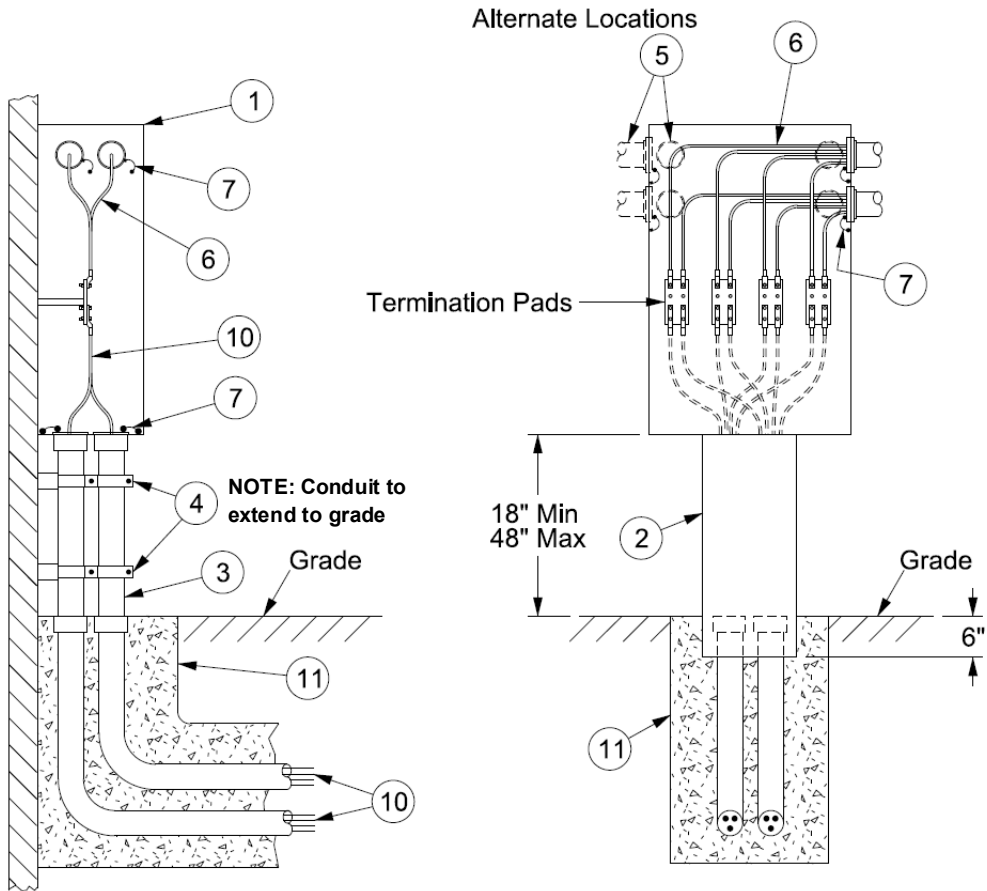

Side View

WITH SERVICE LATERAL IN CONDUIT

SERVICE TERMINATION IN A TERMINATION COMPARTMENT

ABOVE GRADE – BOTTOM ENTRY AND EXIT

ALL 1Ø VOLTAGES, 400-800A

ALL 3Ø VOLTAGES, 400-3000A

Obtain acceptance for 1Ø installations larger than 400A from the Company

Customer furnishes and installs:

1. Company listed termination compartment (see Note 1 & D-19).
2. Termination pads (see Note 2).
3. Service lateral conduit 1200-3000A (see Note 3).
4. Conduit supports, 2 minimum.
5. Service entrance conduit (see Note 4).
6. Service entrance conductors (see Note 5).
7. Bonding. Metallic conduit shall be bonded.
8. 90° metallic elbow (see Note 6).
9. Insulated conduit bushing.

Company furnishes and installs:

10. Service lateral with compression lug terminations (600A +) (see Note 7)
11. Conduit package.

Notes:

1. The termination compartment may be bonded to the neutral termination pad.
2. The termination pads are to be raised to their highest position.
3. Galvanized rigid or galvanized intermediate conduit with threaded ends and threaded fittings at the termination compartment are required.. For concrete encased laterals, the lower ends are not required to be threaded. Conduits are to be located on 6" centers, in the front of the compartment, and extend to grade level. Reference page U-3 for the proper number and size of the conduits and U-4 for conduit details. Contact the We Energies job representative for approval.
4. The customer service entrance conduits shall be located as shown on U-17 for the style of termination compartment used. The Company service lateral conductors are to terminate on the termination pads as per U-17.
5. The customer's service entrance conductors are to terminate on the termination pads as per U-17 and shall leave the termination compartment as a maximum of two circuits, regardless of the number of conductors per phase. They shall not share bolts with the service lateral.
6. The ends of the galvanized rigid or galvanized intermediate 90° metallic elbows shall be threaded and threaded couplings are to be used.
7. Raceways are not to be used with the bottom entry and exit style of installation.

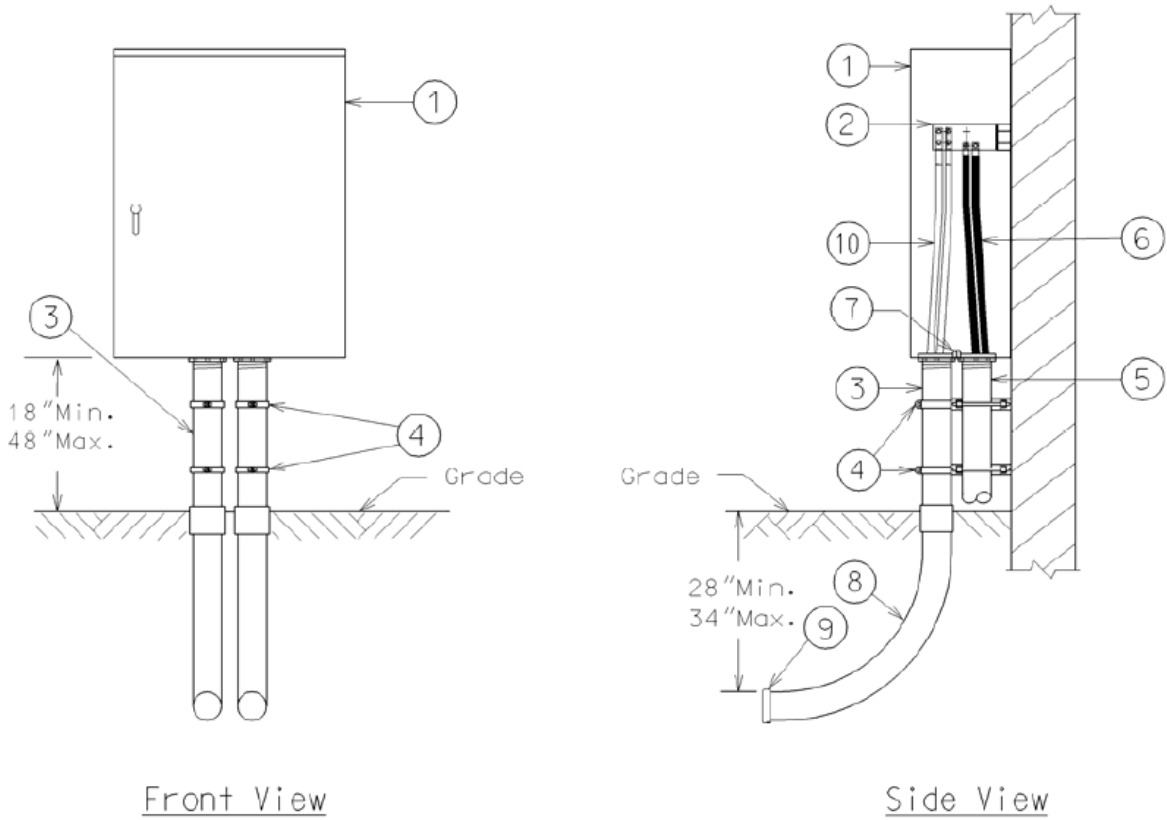

WITH DIRECT BURIED SERVICE LATERAL

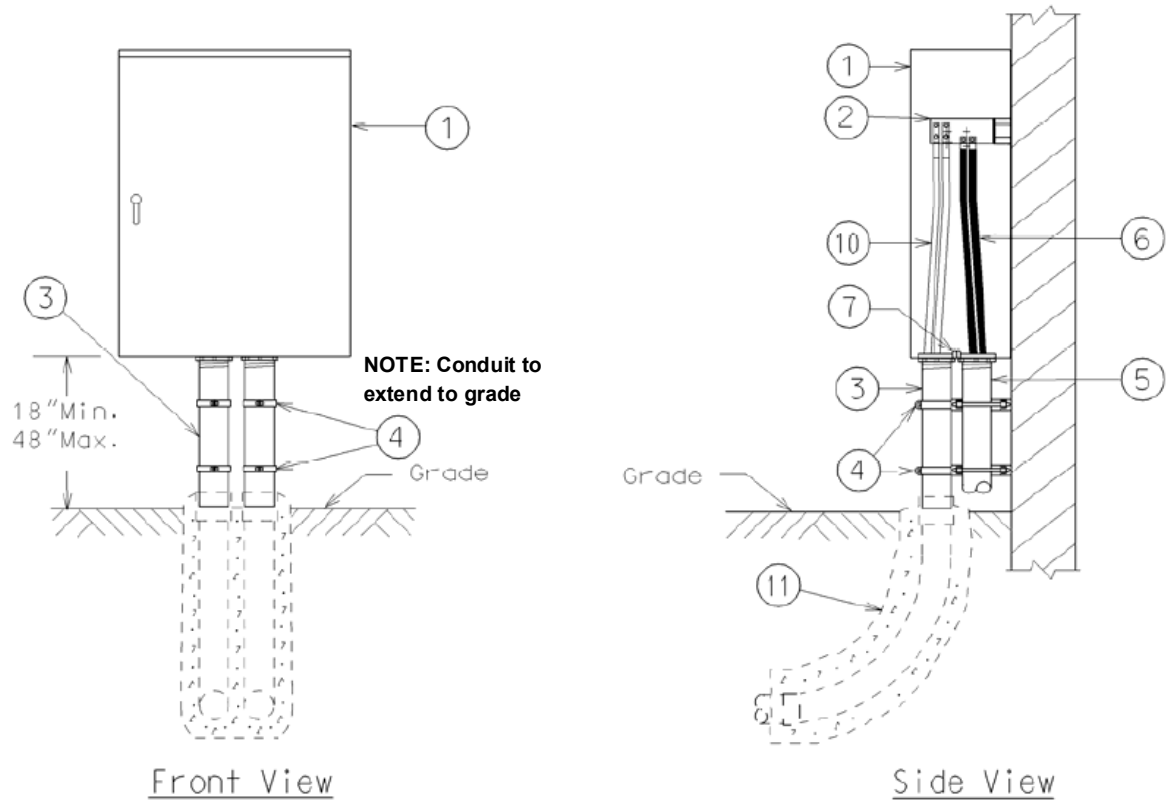

WITH CONCRETE ENCASED SERVICE LATERAL

SERVICE TERMINATION IN A TERMINATION COMPARTMENT

FREE STANDING – BOTTOM ENTRY AND EXIT

ALL 1Ø VOLTAGES, 400-800A

ALL 3Ø VOLTAGES, 400-3000A

Obtain acceptance for 1Ø installations larger than 400A from the Company

Customer furnishes and installs:

1. Company listed termination compartment (see Note 1 & D-19).
2. Termination pads (see Note 2).
3. Service lateral conduit 1200-3000A (see Note 3).
4. Conduit supports, 2 minimum.
5. 90° metallic elbow, 36" radius (see Note 6).
6. Service entrance conduit (see Note 4).
7. Service entrance conductor (see Note 5).
8. Bonding. Metallic conduit shall be bonded.
9. Insulated conduit bushing.
10. Structure supports (see Notes 8, 9 & 10).
11. Concrete footing, 2" min. diameter.
12. Galvanized steel framing channel, 1-5/8" x 1-5/8" x 12 Ga.

Company furnishes and provides:

13. Service lateral with compression lug terminations (600A +) (see Note 7).
14. Conduit package.

Notes:

1. The termination compartment may be bonded to the neutral termination pad.
2. The termination pads are to be raised to their highest position.
3. Galvanized rigid or galvanized intermediate conduit with threaded ends and threaded fittings at the termination compartment are required.. For concrete encased laterals, the lower ends are not required to be threaded. Conduits are to be located on 6" centers, at the front of the compartment, and extend to grade level. Reference page U-3 for the proper number and size of the conduits and U-4 for conduit details. Contact the We Energies job representative for approval.
4. The customer service entrance conduits shall be located as shown on U-17 for the style of termination compartment used. The Company service lateral conductors are to terminate on the termination pads as per U-17.
5. The customer's service entrance conductors are to terminate on the termination pads as per U-17 and shall leave the termination compartment as a maximum of two circuits, regardless of the number of conductors per phase. They shall not share bolts with the service lateral.
6. The ends of the galvanized rigid or galvanized intermediate 90°, 36" radius, metallic elbows shall be threaded and threaded couplings are to be used.
7. To prevent water from entering the structure supports, they must be either capped or filled with concrete.
8. The supports must be spaced far enough apart to allow the service entrance conduits to pass between them. To calculate the minimum distance needed between the supports (center to center) use the formula $(6 \times n) + d$. Where "n" is the number of conduits and "d" is the diameter of the footings.
9. For 400 – 1600 A services, use 3" galvanized rigid conduit supports. For 2000 – 3000 A services, use 4" rigid galvanized conduit supports.
10. Raceways are not to be used with the bottom entry and exit style of installation.

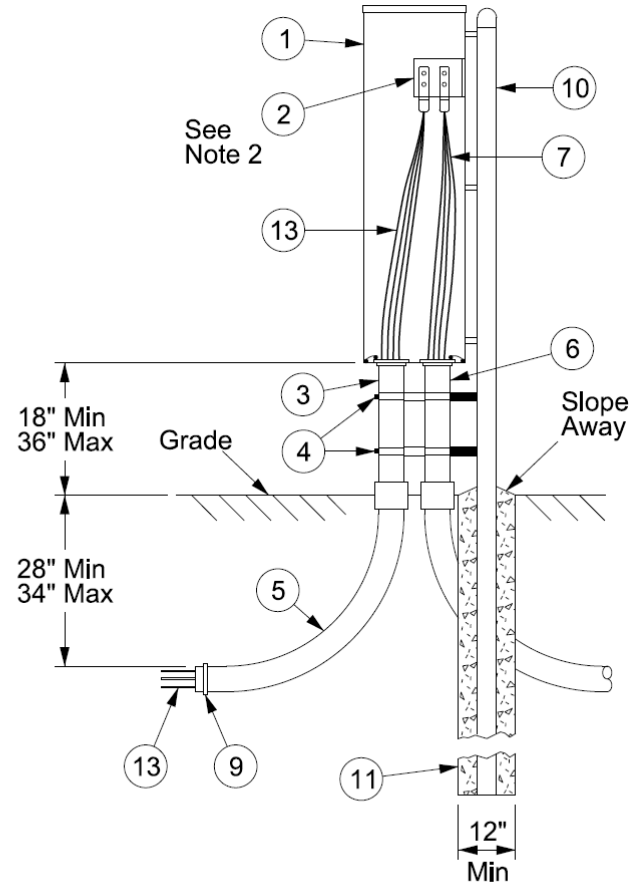
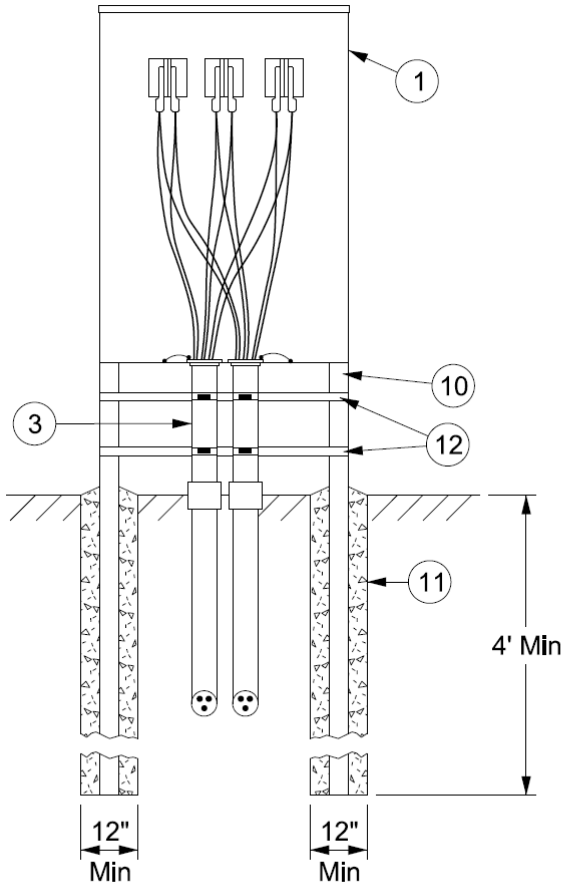

Direct Buried Service Lateral

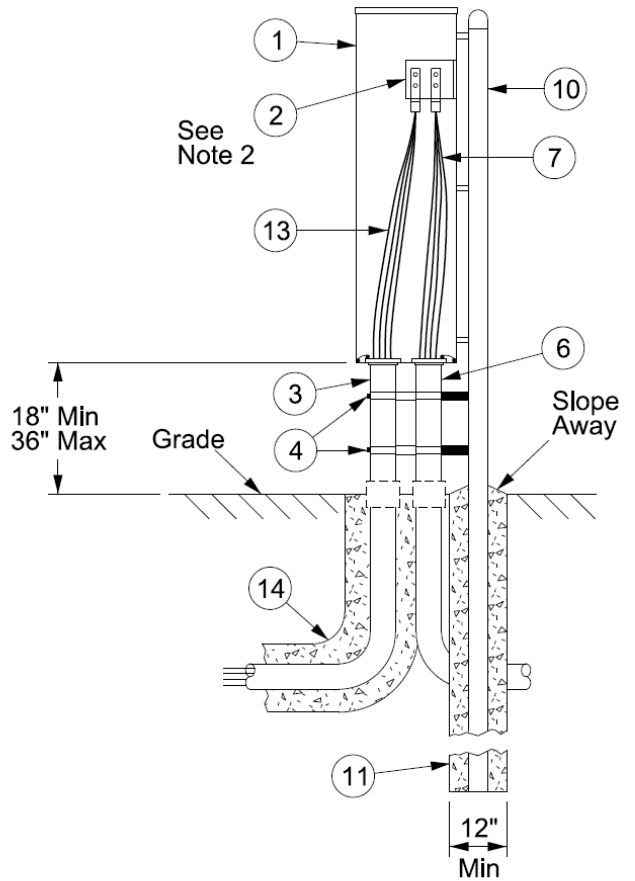
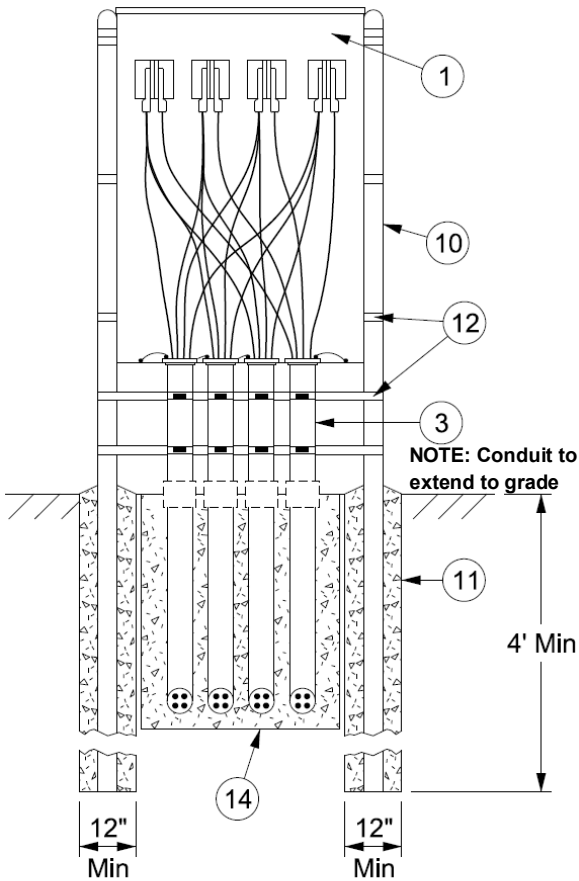

Concrete Encased Service Lateral

SERVICE TERMINATION IN A TERMINATION COMPARTMENT

PADMOUNTED – BOTTOM ENTRY AND EXIT

ALL 1Ø VOLTAGES, 400-800A

ALL 3Ø VOLTAGES, 400-4000A

Obtain acceptance for 1Ø installations larger than 400A from the Company

Customer furnishes and installs:

1. Company listed termination compartment (see Note 1 & D-22).
2. Termination pads (see Note 2).
3. Service lateral conduit 400-4000A (see Notes 3 & 4).
4. Service entrance conduit (see Note 4).
5. Service entrance conductors (see Note 5).
6. 4" 90° elbow with 36" radius (see Note 8).
7. Insulated conduit bushing.
8. Concrete pad (see Note 7).

Company furnishes and installs:

9. Service lateral with compression lug terminations (600A +) (see Note 6)
10. Conduit package.

Notes:

1. The termination compartment may be bonded to the neutral termination pad.
2. The termination pads are to be raised to their highest position.
3. Schedule 40 PVC, galvanized rigid, or IMC conduit shall extend to be slightly higher than level with the top of the concrete pad (no more than 3" higher). If used, metallic conduit shall be bonded. Reference U-3 for the number and proper size of the conduits and U-4 for conduit details. Contact the We Energies job representative for approval.
4. The customer service entrance conduits shall be located as shown on U-17 for the style of termination compartment used. The Company service lateral conductors are to terminate on the termination pads as per U-17.
5. The customer's service entrance conductors are to terminate on the termination pads as per U-17 and shall leave the termination compartment as a maximum of two circuits, regardless of the number of conductors per phase. They shall not share bolts with the service lateral.
6. The concrete pad shall be 6" thick and 3-5" wider and deeper than the termination compartment.
7. The 90° elbows shall face the transformer. See layout drawing provided by the Company.

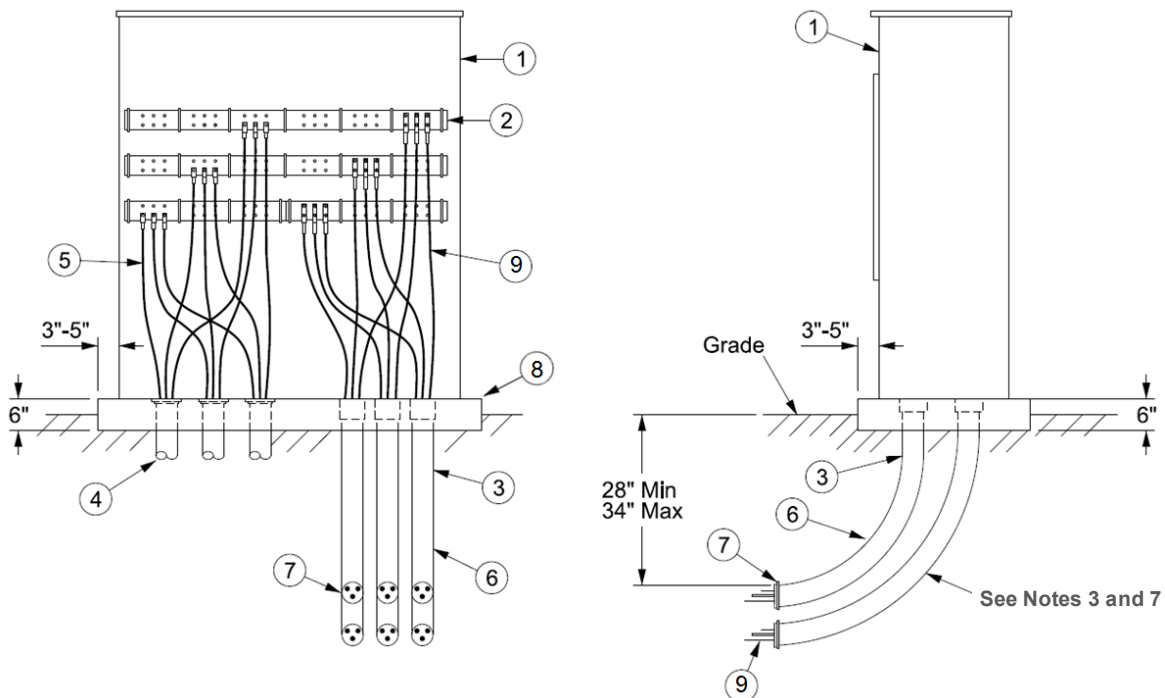

SERVICE TERMINATION IN A TERMINATION COMPARTMENT

CONCRETE ENCASED LATERAL – MULTI-METERED INSTALLATIONS

ALL 1Ø VOLTAGES, 400-800A

ALL 3Ø VOLTAGES, 400-3000A

Obtain acceptance for 1Ø installations larger than 400A from the Company

Customer furnishes and installs:

1. Company listed termination compartment (see Note 1 & D-18).
2. Service lateral conduit 400 – 3000A (see Note 2).
3. Conduit supports.
4. Service entrance conduit (see Note 4).
5. Service entrance conductors (see Note 5).
6. Bonding. Metallic conduit shall be bonded.

Company furnishes and installs:

7. Service lateral with compression lug terminations (600A +).
8. Conduit package.

Notes:

1. The termination compartment may be bonded to the neutral termination pad.
2. For concrete encased services 1600A or less, a raceway is preferred (see D-16 for approved raceways). For concrete encased service laterals, raceways shall extend 3" to 6" below final grade. If the raceway cannot be used, such as where the termination compartment is located in a paved area, conduit may be used; see Note 3 for conduit details.
3. Galvanized rigid or galvanized intermediate conduit with threaded ends and threaded fittings at the termination compartment are required. For concrete encased laterals, the lower ends are not required to be threaded. Conduits are to be located on 6" centers and extend to grade level. Reference page U-3 for the proper number and size of the conduits and U-4 for conduit details. Contact the We Energies job representative for approval.
4. If the service entrance conduits are located above the termination pads, watertight hubs or sealing locknuts are required. When the service entrance conduit enter box at the top, watertight hubs are required.
5. The customer's service entrance conductors shall leave the termination compartment as a maximum of two circuits, regardless of the number of conductors per phase.

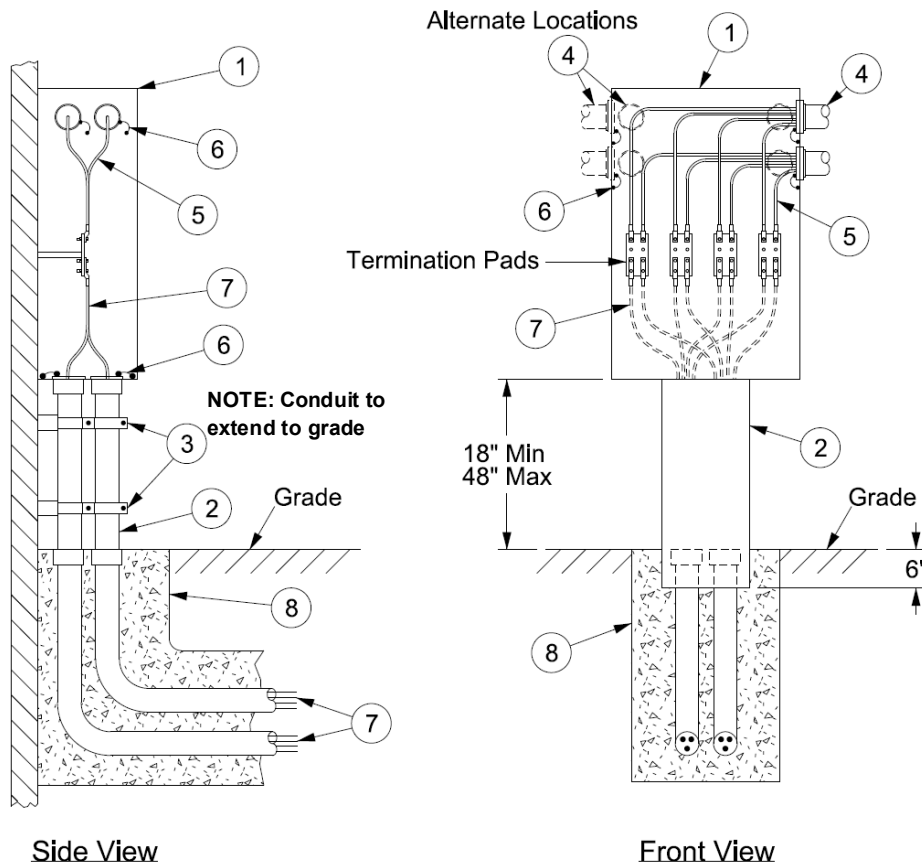

SERVICE TERMINATION IN A TERMINATION COMPARTMENT

BUILDING WITHOUT A BASEMENT – FIRST FLOOR INSTALLATION – MULTI-METERED INSTALLATIONS

ALL 1Ø VOLTAGES, 400-800A

ALL 3Ø VOLTAGES, 400-3000A

Obtain acceptance for 1Ø installations larger than 400A from the Company

Company furnishes and installs:

1. Company listed termination compartment (see Note 1 & D-18).
2. Service lateral conduit (see Note 2).
3. 4" I.D. 90° elbow (see Note 2).
4. Steel reinforcing rods, 5/8" x 6'.
5. Conduit spacers.
6. Continuous concrete envelope with a minimum of 3" of concrete on all sides.
7. Bonding. Metallic conduit shall be bonded.
8. Service entrance conduit.
9. Service entrance conductors (see Note 3).
10. Temporary watertight end caps.

Company furnishes and installs

11. Service entrance conduit, coupling, & concrete envelope.
12. Service lateral with compression lug terminations (600A +).

Notes:

1. The termination compartment may be bonded to the neutral termination pad.
2. Galvanized rigid or galvanized intermediate conduit with threaded ends, or rigid nonmetallic schedule 40 PVC is acceptable. Reference page U-3 for the proper number and size of the conduits required and U-4 for conduit details. Contact the We Energies job representative for approval.
3. The customer's service entrance conductors shall leave the termination compartment as a maximum of 2 circuits, regardless of the number of phases per conductor.
4. Conduit for direct buried installations shall extend a minimum of 12" into undisturbed earth.

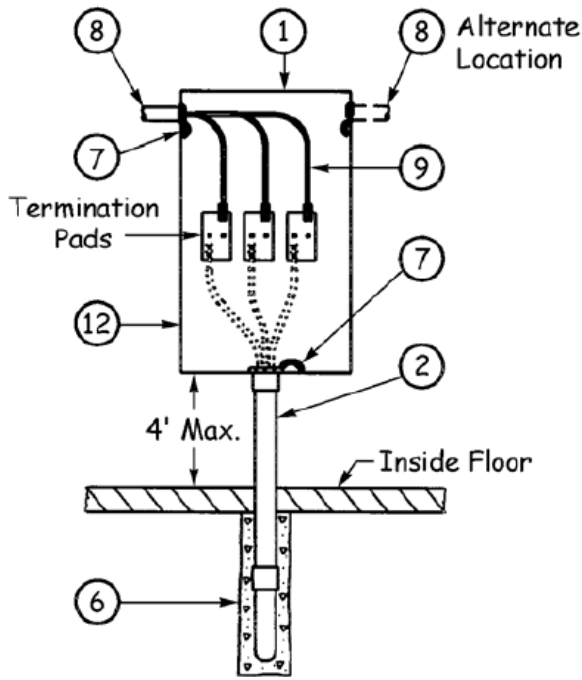

Front View

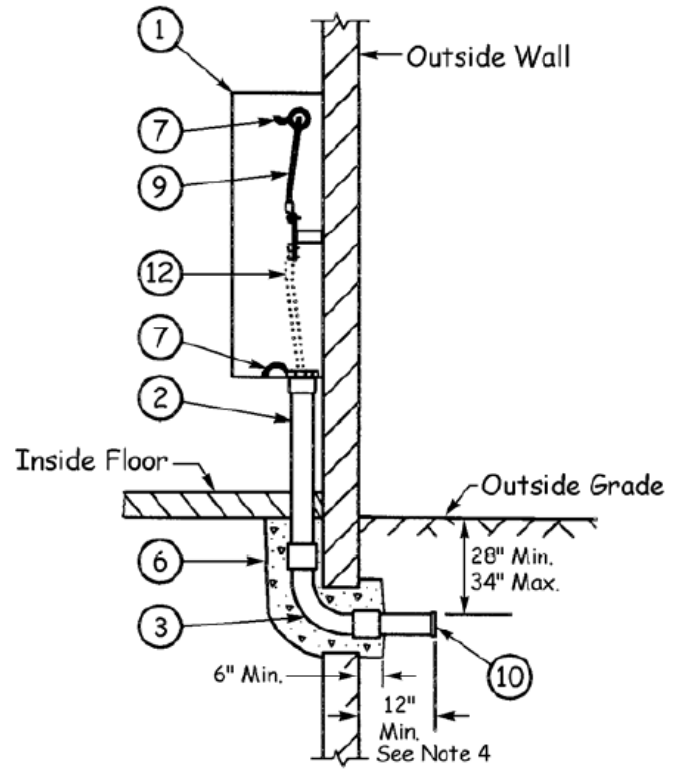

Side View

WITH DIRECT BURIED SERVICE LATERAL

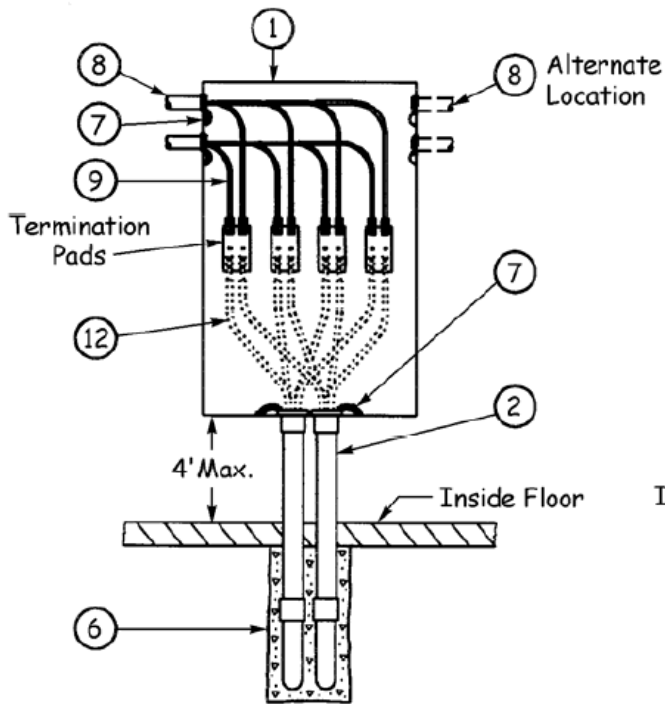

Front View

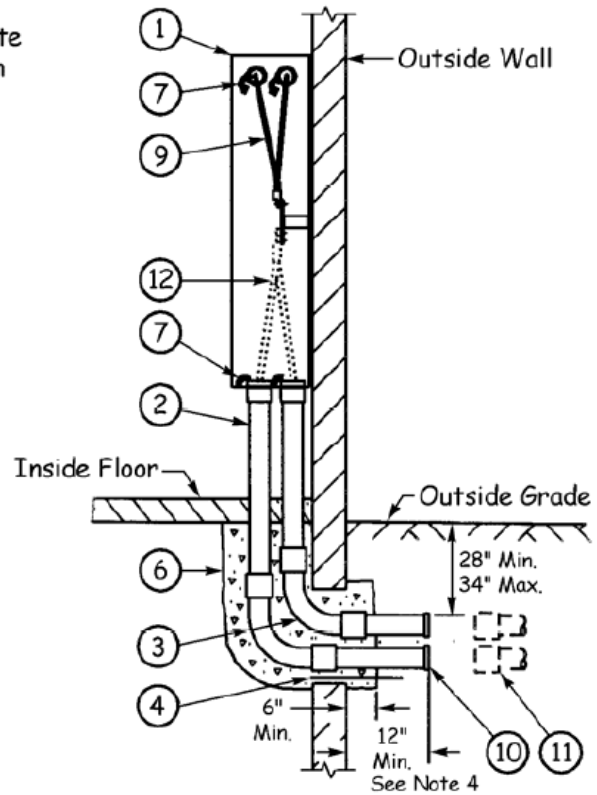

Side View

WITH CONCRETE ENCASED SERVICE LATERAL

SERVICE TERMINATION IN A TERMINATION COMPARTMENT

CONCRETE ENCASED LATERAL – LOCATED BELOW GRADE

CONDUIT AND MANHOLE SYSTEM ONLY

ALL 1Ø VOLTAGES, 400-800A

ALL 3Ø VOLTAGES, 400-3000A

REQUIRES COMPANY APPROVAL (SEE NOTE 4)

Customer furnishes and installs:

1. Company listed termination compartment (see Note 1 & D-20).
2. Service lateral conduit (See Note 2).
3. Terminal adapter with locknuts and insulated bushing.
4. Steel reinforcing rods, 5/8" x 6'.
5. Continuous concrete envelope with a minimum of 3" of concrete on all sides.
6. Service entrance conduit. Metallic conduit shall be bonded.
7. Service entrance conductors (see Note 3).
8. Temporary watertight end cap.

Company furnishes and installs:

9. Service lateral conduit, concrete encased.
10. Service lateral with compression lug terminations (600A +).

Notes:

1. The termination compartment may be bonded to the neutral termination pad. Only termination compartments listed on Page D-20 as for use below grade are to be used. These units have termination pads that are adjustable to obtain the 24" min. from the top of the pad to the bottom of the conduits.
2. 4" rigid nonmetallic schedule 40 PVC conduit per NEMA standard TC-2. Conduits are to be arranged horizontally and 6" on center as shown Reference page U-3 for the proper number and size of the conduits required and U-4 for conduit details. Contact the We Energies job representative for approval.
3. The customer's service entrance conductors shall leave the termination compartment as a maximum of two circuits, regardless of the number of conductors per phase.
4. **Send copies of the drawings of the switchgear termination and metering compartments to the local We Energies job representative for acceptance prior to any construction.**

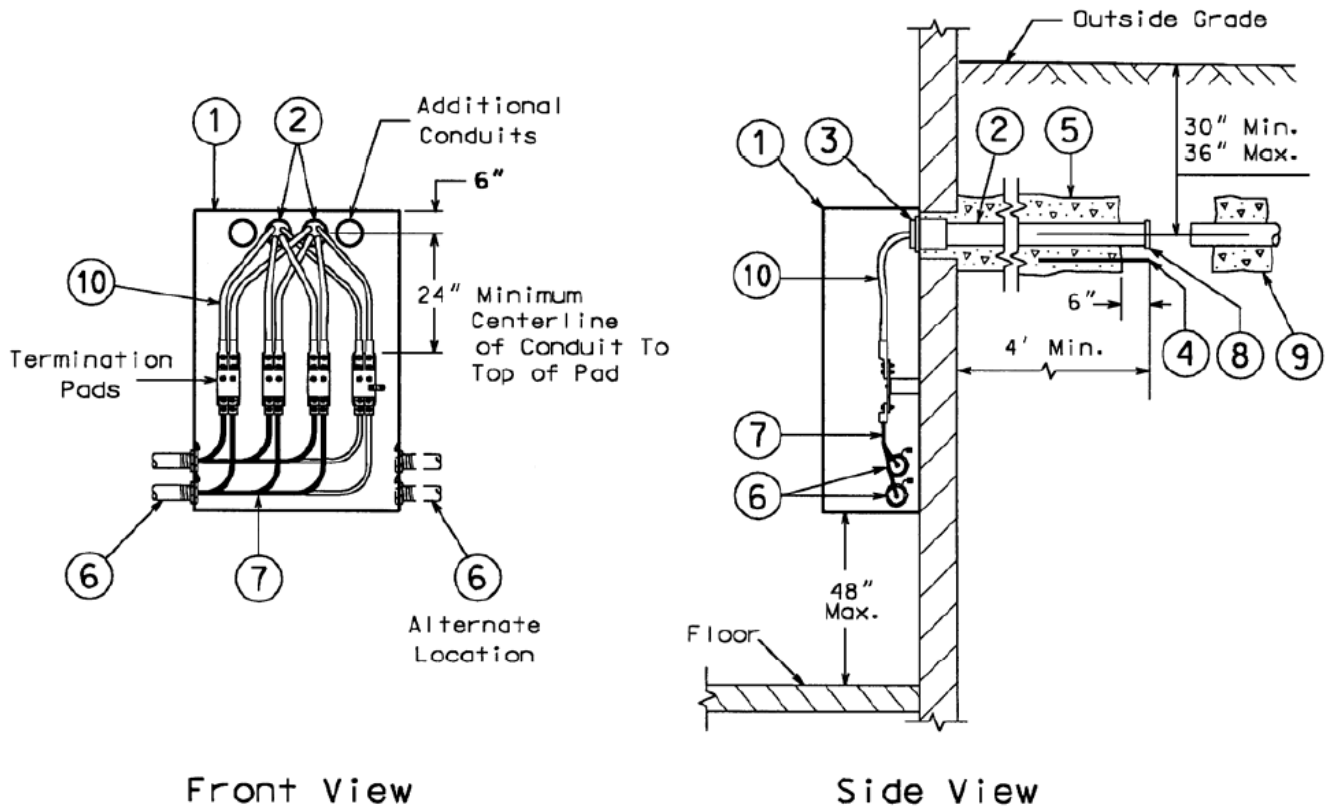

SERVICE TERMINATION IN A TERMINATION COMPARTMENT

FREE STANDING SWITCHGEAR – LOCATED ON FIRST FLOOR OR ABOVE

ALL 3Ø VOLTAGES, 2000-4000A

REQUIRES COMPANY APPROVAL (SEE NOTE 5)

Customer furnishes and installs:

1. Completely enclosed termination compartment with rigidly supported bus bars, located and drilled as shown (see Notes 1 through 4).
2. 4" schedule 40 PVC conduit, concrete encased. (see Note 8).
3. Temporary watertight end caps.
4. Reinforcing rods (epoxy coated re-bar).
5. 4" schedule 40 PVC, 90° elbows with 36" radius.

Company furnishes and installs:

6. Service lateral conduit and concrete envelope (not shown). We Energies does not lace cables.
7. Service lateral with compression lug terminations (not shown).

Notes:

1. Rigidly supported barriers shall separate the termination compartment from other compartments.
2. Front panels are to be removable, sealable, have hasps for padlocking, and when removed shall leave a clear and unobstructed opening exposing only the service lateral termination area. All other panels shall be installed in their original position on the switchgear prior to We Energies terminating cables.
3. Only the service lateral conductors are allowed in this termination compartment. The grounding electrode conductor shall NOT pass through, or terminate in, this compartment; nor shall bonding of the neutral and grounding buses be done in this compartment.
4. Bus work shall be labeled in each compartment to easily identify phases.
5. **Send copies of the drawings of the switchgear termination and metering compartments to the local We Energies job representative for acceptance prior to any construction.**
6. The dimension shown is from the top of the conduit to the lower hole in the bus bar. For 3Ø, 3 wire installations, omit the neutral bus and use the 40" dimension.
7. The preferred termination of service laterals is on the outside of a building (or structure). Service laterals that terminate inside of a building shall terminate immediately upon entering as shown in this manual. The raceway for service laterals under or through a building shall not extend longer than 8' after penetrating the outside wall; this is a We Energies requirement (see U-2 Note 3) in addition to the State of Wisconsin requirement. The only bend allowed in the duct package is the 90° bend to enter the termination compartment.
8. Where the termination compartment is located on a mezzanine, a continuous duct package must be installed with a maximum distance of 14' from final grade to the bottom of the termination compartment.
9. See pages M-20 and M-21 for metering details.
9. Reference U-4 for conduit details and width table. Conduit shall be installed so the duct package width is parallel with the bus. See the drawings below.

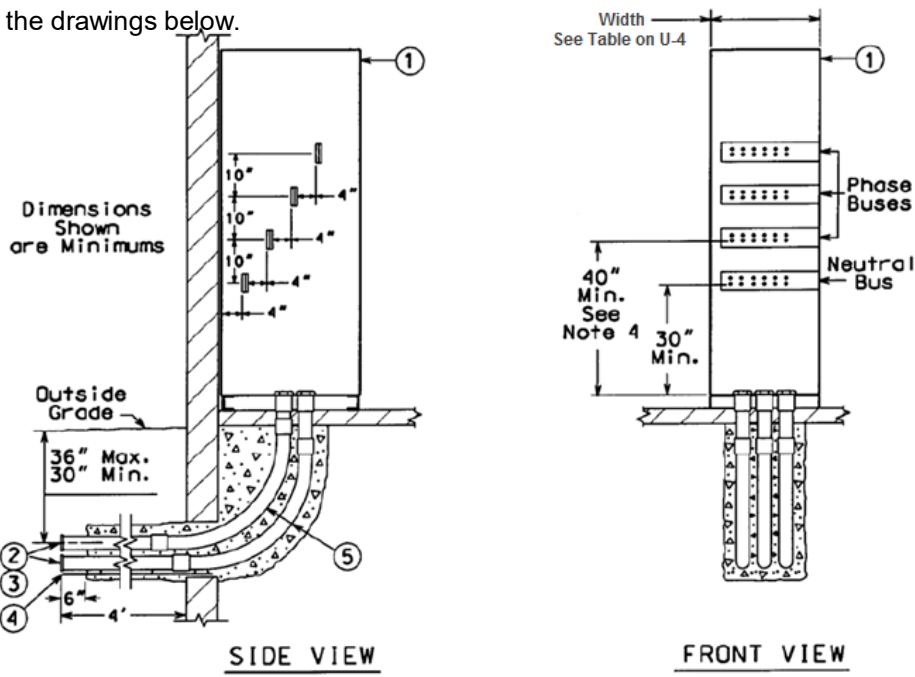

COMMUNICATION TOWERS

POLICY ON SERVICES

NEW SERVICES

We Energies policy is to provide one electric service to each tower site. This service must be sized to accommodate present and future carriers that have space on the tower with a meter position for each carrier. Applications for service to tower sites shall include information on each tower's capacity (i.e. total number of carriers the tower will accommodate). This information is a requirement for electric service to the tower site.

If additional carriers are allowed space on the tower and the size of the service or number of meter sockets need to be increased, the owner shall be responsible for increasing the size of the service and/or the number of meter sockets. Additional services **laterals** are not permitted.

EXISTING SERVICES

For existing towers, the owner will **need to request to** install a multi-position metering bank to serve the **total** number of tenants that may attach to the tower in the future.

COMMUNICATION TOWERS

SERVICE TERMINATION IN A FREE STANDING MULTI-POSITION METER SOCKET – DIRECT BURIED LATERAL

1Ø 120/240 VOLTS, 0-800A
0-200A PER METER, 2-6 METERS

Customer furnishes and installs:

1. Service entrance conduit.
2. Service entrance conductors.
3. Metallic conduit shall be bonded.
4. Company listed 2 – 6 position meter socket (see Notes 1 & 4 and sheet D-8).
5. Service lateral conduit (see Note 2).
6. Insulated conduit bushings (see Note 3).
7. 4" galvanized rigid or IMC 90° elbow with 24" radius. (see Note 6)
8. Galvanized steel framing channel, 1-5/8" x 1-5/8" x 12 Ga.

Customer furnishes and installs:

9. Conduit clamps.
10. 3' galvanized rigid with galvanized end cap (see Note 5).
11. Concrete footing (12" minimum hole size).

Company furnishes and installs:

12. Service lateral.
13. Watthour meters.

Notes:

1. Separate cable compartment is provided for the Company's service lateral cables only.
2. 4" galvanized rigid or galvanized intermediate conduit with threaded ends and fittings. Reference page U-3 for the proper number and size of the conduits required and U-4 for conduit details. Contact the We Energies job representative for approval.
3. Service lateral conduits shall extend underground to a point outside of fenced area and have temporary waterproof end caps to prevent the accumulation of water, ice, and other foreign matter inside the conduits.
4. Each meter position shall be marked on the outside of the socket or by the breaker (if available) with the address of the unit served. If the marking is on the outside of a removable cover, it shall also be marked on the inside of the meter socket in a visible location. This marking shall also be placed on the corresponding distribution panel(s). The marking shall be a permanent label with ½" block letters and may consist of individual self-stick letters or numbers, suitable for the location so as to be considered permanent.
5. As an alternative item to Item 10 above, 4" x 4" x 3/8" galvanized steel angle may be used.
6. **If conduit extends past the 90 degree elbow, transition to schedule 40 PVC. Customer is to match burial depth of the company. Please send conduit plans to the company for acceptance.**

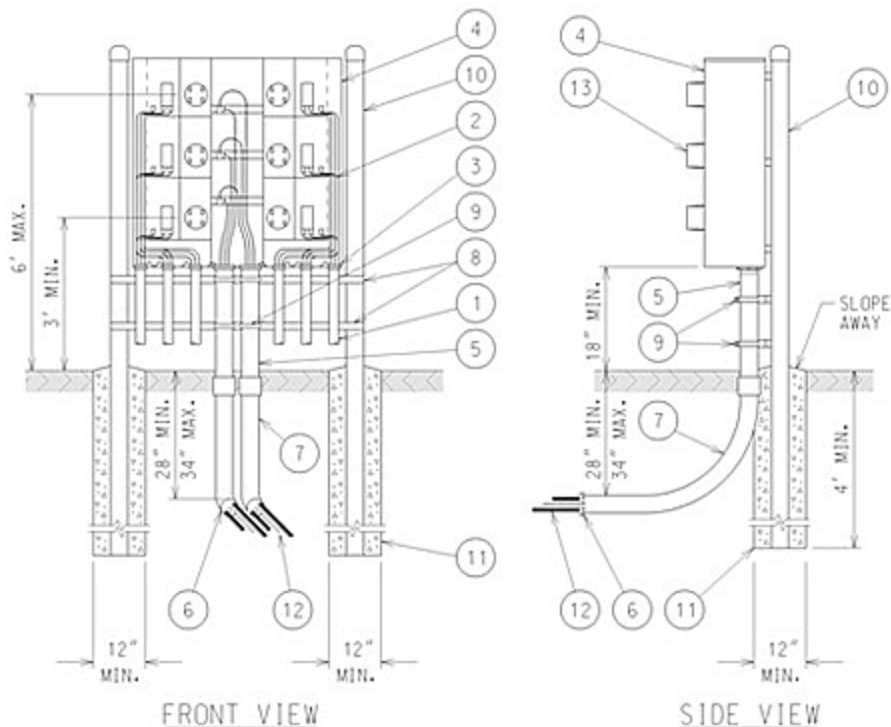

METERING – SECONDARY

• General requirements for metering	M-2
• Meter socket mounting	M-5
• Guards for outdoor installations	M-6
Meter socket with overhead service entrance	
• 1Ø, 2-wire, all voltages, 0-100 amps	M-7
• 1Ø, 3-wire, 120/240 volts, 0-320 amps.....	M-8
• 1Ø, 3-wire, 208Y/120 volts, 0-100 amps	M-9
• 3Ø, 4-wire, 208Y/120 or 480Y/277 volts, 0-200 amps.....	M-10
Meter socket for customer owned streetlighting	
• 1Ø, 3-wire, 240/480 volts (grounded), 0-200 amps.....	M-11
Meter pedestal with underground service lateral	
• 1Ø, 2-wire, 120 volts, 0-30 amps	M-12
• 1Ø, 2-wire, 480 volts (ungrounded), 0-100 amps (maintenance only)	M-12
• 1Ø, 3-wire, 120/240 or 240/480 volts, 0-200 amps	M-13
• 1Ø, 3-wire, 120/240 volts, 320 amps.....	M-14
• 1Ø, 3-wire, 208Y/120 volts, 0-100 amps	M-15
• 3Ø, 4-wire, 208Y/120 or 480Y/277 volts, 0-200 amps.....	M-16
Transocket with overhead service entrance	
• 1Ø, 3-wire, 120/240 volts, 400-800 amps.....	M-17
• All 3Ø voltages, 400-2000 amps	M-17
Transocket with underground service entrance	
• 1Ø, 3-wire, 120/240 volts, 400-800 amps.....	M-18
• All 3Ø voltages, 400-2000 amps	M-18
• 3Ø, 4-wire, 208Y/120 volts or 480Y/277 volts, 400-4000 amps.....	M-18
Outdoor current transformer metering with customer disconnect	
• 1Ø, 3-wire, 120/240 volts, 400-800 amps.....	M-19
• All 3Ø voltages, 400-1200 amps	M-19
Meter stack socket breaker installation	
• All 1Ø, 3-wire voltages, 0-200 amps.....	M-20
• All 3Ø voltages, 0-200 amps.....	M-20
Current transformer metering in free standing switchgear	
• 1Ø, 3-wire, 120/240 volts, 400-800 amps.....	M-21
• All 3Ø voltages, 400-4000 amps	M-21
Modular Metering in freestanding switchgear	
• 1Ø, 3-wire, 120/240 or 208Y/120 volts, 0-200 amps per meter	M-23
• All 3Ø voltages, 0-200 amps per meter	M-23
Maintenance Only	
• OH Meter Socket 3Ø, 3-wire, 240 or 480 volts (ungrounded), 0-200 amps	M-24
• UG Meter Socket 1Ø, 3-wire, 120/240 volts, 0-200 amps	M-25
• UG Meter Socket 1Ø, 3-wire, 208Y/120 volts, 0-100 amps.....	M-26
• UG Meter Socket 3Ø, 3-wire, 240 volts or 480 volts (ungrounded), 0-200 amps	M-26
• UG Meter Socket 3Ø, 4-wire, 208Y/120 or 480Y/277 volts, 0-200 amps.....	M-27
• UG Meter Pedestal 3Ø, 3-wire, 240 or 480 volts (ungrounded), 0-200 amps	M-28
Appendix	
• Choosing the proper meter socket	i
• Residential deck procedure	iii
• Meter protection from Snow and Ice.....	iv

GENERAL REQUIREMENTS FOR METERING

General

The information covered in this section is applicable to overhead, underground, substation, and AC network sources of supply covered in the foregoing sections of the manual.

Location of Meters and Metering Equipment

1. Outdoor metering is required for residential, one or two customer, and farm installations with 1-phase service of 200 amperes or less.
2. Meters shall be installed outdoors in cases such as summer dwellings and other premises not occupied during the entire year or not accessible during regular working hours of Company personnel.
3. For outdoor installations with an OH service drop, the centerline of all meters shall be between 4 and 6 feet from finished grade.
4. For outdoor installations with an UG service lateral, the centerline of all meters shall be between 3 and 6 feet from the finished grade.
5. For indoor installations, locate meters in the basement or other suitable and readily accessible place as near as possible to the point where the service enters the building. The centerline of all meters shall be between 4 and 6 feet above the floor (not applicable to ganged or grouped installations of more than 2 units as covered in Requirement 6 below).
6. For indoor group installations, the centerline of all meters shall be between 2 and 6 feet above the floor. For apartment, commercial, and other appropriate buildings of more than 2 floors, meters may be located on different floors of the building provided they are grouped in enclosures as near as practicable to the risers serving the floors and the wiring and metering layout for the building is accepted by the Company.
7. For multiple unit buildings (two or more), **single-family buildings with multiple meters, and termination compartment when applicable**, each meter position shall be marked on the outside of the socket or by the breaker (if available) with the address of the unit served. If the marking is on the outside of the removable cover, it shall also be marked on the inside of the meter socket in a visible location. This marking shall also be placed on the corresponding distribution panel(s). The marking shall be a permanent label with ½" block letters and may consist of individual self-stick letters or numbers, suitable for the location so as to be considered permanent.
8. There shall be a 4" clearance around the meter from all foreign objects.
9. There shall be a 3' minimum of unobstructed working space, measured from the meter face, in front of all meters. This space shall extend from the floor or grade to a height of 6'-6". At least one entrance of sufficient area shall be provided to give access to this working space.
10. The unobstructed space required in front of meter cabinets, CT compartments, and transformer loss compensation cabinets shall be as defined by the "Working Space About Electrical Equipment" section 110.26 of the **National Electric Code** (latest revision as adopted by the states of Michigan and Wisconsin). This unobstructed space shall extend from the floor, or ground, to a height of 6'-6". Equipment doors are required by the NEC to open a minimum of 90°.
11. Ample space shall be provided for all meters, metering equipment, and other apparatus so that they can be safely read, inspected, and tested. If meters are placed near areas of vehicular traffic, guards shall be installed (see M-5). Meter equipment shall not be located:
 - a. In animal enclosures, attics, closets, elevator or ventilating shafts, hallways, living quarters, stairways, or rooms contain corrosive or explosive vapors (battery rooms).
 - b. Near stoves, radiators, steam or hot water pipes, or within 5' of moving machinery.
 - c. Above laundry equipment, plumbing fixtures or other bulky equipment.
 - d. Behind shrubbery or swinging doors, or over alleys, driveways, decks or porches (or over sidewalks where practicable), or where it is necessary to trespass on adjacent property.
 - e. In hazardous locations as defined in articles 500 to 516 of the **National Electric Code** as amended in Michigan by the **Michigan Administrative Code** and as amended in Wisconsin by the **Wisconsin Administrative Code**.
 - f. Where subject to damage from falling ice, snow or other debris. If the metering equipment cannot be moved to an area free of these hazards the necessary protection may be provided by a roof overhang or gutter that extends a minimum of 12" past the face of the meter socket. In place of the roof overhang the customer shall provide and install a deflector that shall extend 12" past the face of the meter socket and be installed at a height greater than 6'-6" to comply with Requirements 9 & 10 above.

12. Meter locations shall be free from excessive moisture, vibrations, and heat. Meters shall not be placed on partitions, insecure walls, or over doorways. Meters shall be shielded from magnetic disturbances and protected from mechanical damage, moving machinery, and belts by means of a suitable protecting cabinet.
13. 3' clearance between gas and electric metering equipment shall be provided. See G4 for details.

Methods of Mounting Metering Equipment

1. Socket-type meter mounting devices installed on concrete or masonry walls shall be fastened by non-corrosive metal machine screws in lead sleeve, wedge-type expansions anchors.
2. All mounting devices for metering equipment shall be plumb.

Methods of Wiring Service Equipment and Meters

1. The knockouts of meter pedestals, sockets, or transockets shall not be used for service entrance conductors unless the knockouts are located entirely below the lowest live parts.
2. Metered and unmetered conductors shall not be installed in the same conduit, raceway, channel, gutter, or similar enclosure.
3. Where a group of meters is supplied from a service raceway, the covers of the raceway must be provided with a means for sealing where individual service taps are made into the raceway.
4. Termination compartments, meter mounting devices, or CT compartments shall not be used as junction boxes, pull boxes, raceways, or similar wire enclosure for additional customer circuits. **Once the service entrance or feeder conductors exit the termination compartment, meter mounting device, or CT compartment they shall not re-enter the termination compartment, meter mounting device, or CT compartment.**
 - a. This includes taps for emergency circuits or fire alarms.
 - b. At single metered installations where 2 to 6 disconnects are used in place of a single main disconnect, a customer owned junction box or switchboard section shall be installed on the load side of all Company facilities for the purpose of making taps to the individual disconnects.
 - c. Customer provided termination compartments and transockets are permitted to have up to 2 circuits exiting them.
5. Sockets shall be equipped with blank covers furnished by the customer at the time of installation.
6. The rating of a single service switch or the combined rating of all service switches connected to a 1-phase 120/240 volt service shall not exceed 400 amperes unless accepted by the company.
7. A common grounding conductor shall be used to ground the service entrance equipment and the grounded circuit conductor. A grounding conductor shall not be run from the meter socket to ground or through the meter socket, termination compartment or transocket in going from the customer's main service switch or disconnect means to ground. Direct grounding of meter sockets is permissible, only on meter poles where the disconnecting means is installed at some other location. For multi-metered installations the grounding electrode conductor may be bonded to the neutral in a termination compartment. A termination compartment used in conjunction with meter stacks would be considered multi-metered.
8. Service switches/service breakers shall be installed so that any one service switch/breaker, when disconnected, shall not interrupt continuity of service to any other separately metered customer on the premises.
9. All large installations not covered by this Metering Section require special consideration and the Company shall be consulted in all cases. The customer shall submit drawings of the proposed service equipment and metering arrangement to the local We Energies job representative for acceptance.
10. Any service entrance that serves a 24-hour load, 30 days each month of 150 amperes or more, shall have a current transformer metering installation.
11. Any fire pump service where the Full Load Running Amperage (FLRA) of the pump(s) exceeds 125 amperes shall have a current transformer metering installation. **Company's utility conductors and customer's service equipment shall be sized to match the customer's service disconnect.** Due to complexity of fire pump services installed in the downtown Milwaukee area please consult with the local We Energies Application engineer.
12. On outdoor current transformer installations, the meter cabinet and conduit shall be grounded, either by bonding to the service entrance conduit or bus duct.
13. The Company shall meter only those voltages supplied to the customer by the Company; there will be no Company metering after a customer owned stepdown transformer. Any exception to this rule must be reviewed and accepted by the company, and may only be implemented in high rise residential buildings.
14. On new installations it is the company's responsibility to ensure that the meter stops or grounding brackets are clean and provide for a good electrical contact with the meter base.

15. Multi-metered installations shall be installed so as to balance the load on the service.
16. For Communication Tower Policy and Service Termination, see pages U-31 and U-32.
17. Excess service entrance conductor slack shall not be **located** in the service entrance equipment.

METER SOCKET MOUNTING

Customer furnishes and installs:

1. Company listed meter socket.
2. Galvanized bolts, nuts, and washer for mounting meter socket.
3. Galvanized thinwall spacers. They must be as long as the thickness of the finished wall, such as siding, brick, or stone (see Note 1).
4. Horizontally mounted 2"x4" wood supports or #11 gauge minimum thickness steel plates.
5. Studding for the building wall.

Company furnishes and installs:

6. Watthour meter.

Note:

1. The meter socket is to be installed so that it will be securely and permanently mounted both before and after the finished wall is installed. The meter will not be installed until the socket is so mounted.

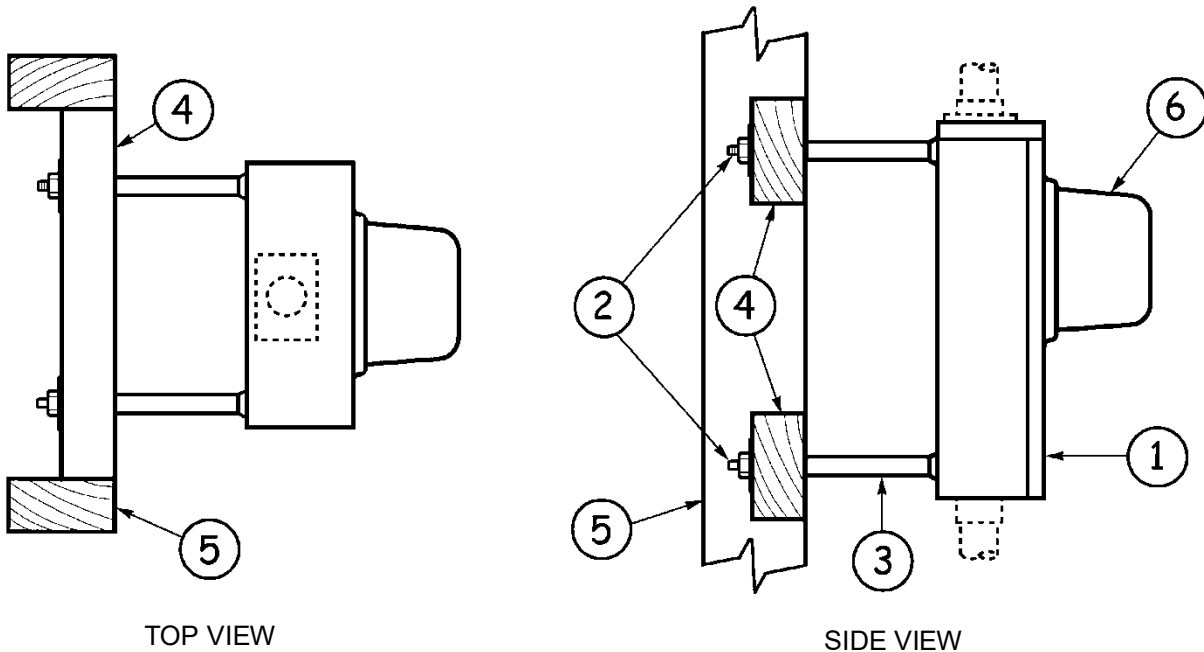

GUARDS FOR OUTDOOR INSTALLATIONS

Customer furnishes and installs:

1. Galvanized steel pipe or schedule 40, 3-1/2" diameter by 6'-6" minimum length and filled with concrete. Approximately 3.4 cu. ft. of concrete is required for the foundation and filling the pipe (see Note 1).
2. Galvanized steel pipe or schedule 40, 6" diameter by 8' minimum length and filled with concrete. Approximately 4 cu. ft. of concrete is required for the foundation and filling the pipe (see Note 1).
3. Concrete footing. A Sono tube is recommended to prevent heaving due to frost.

Notes:

1. The Company shall be consulted concerning the type, placement, and number of guards required.

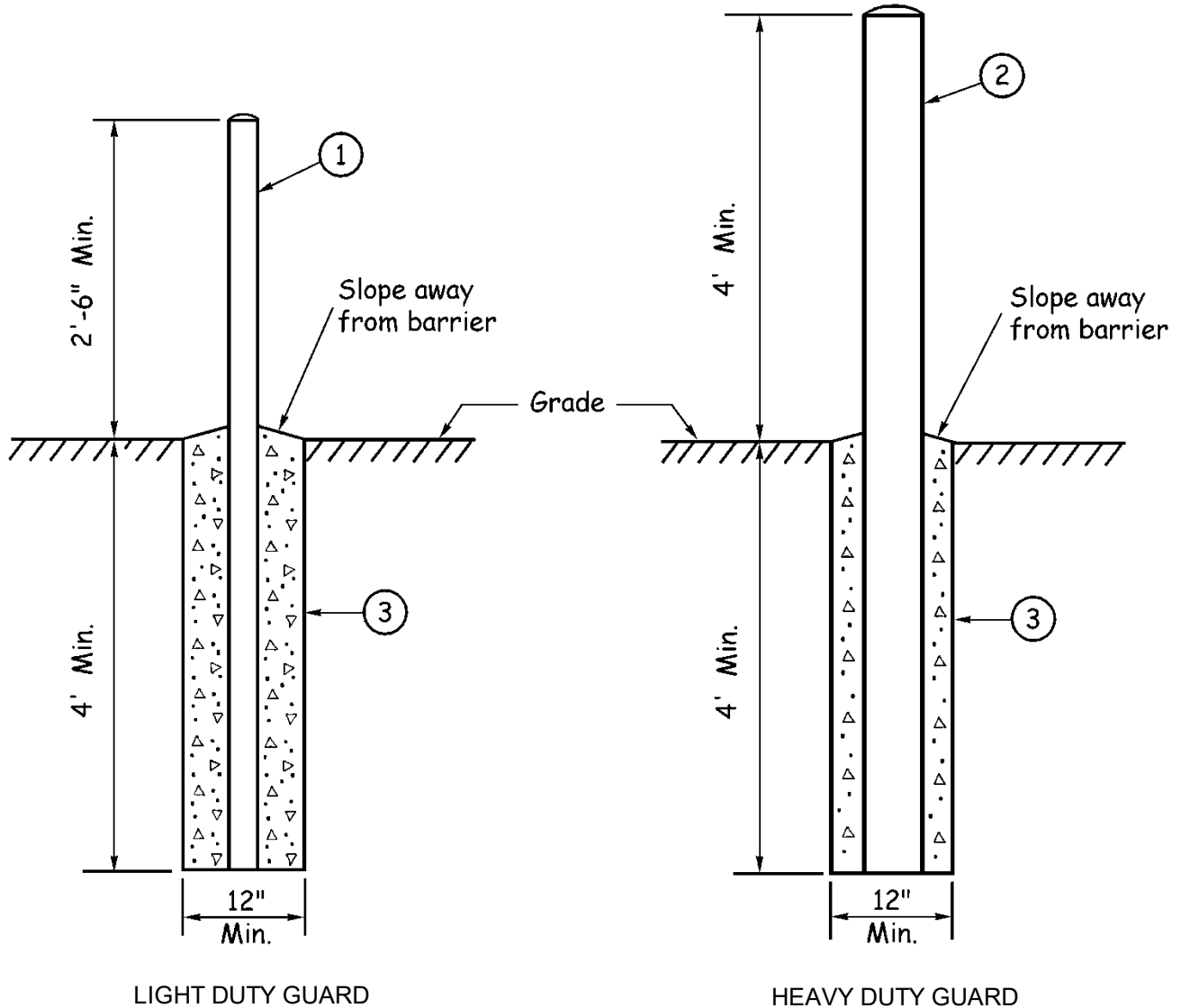

METER SOCKET WITH OVERHEAD SERVICE ENTRANCE

1Ø, 2-WIRE, ALL VOLTAGES, 0-100 AMPS
120 VOLTS, 0-30 AMPS²
277 VOLTS, 0-60 AMPS
240^{3,4} OR 480 VOLTS (UNGROUND⁴ED)⁴, 0-100 AMPS
METERING SEQUENCE: METER-SWITCH-FUSE

Customer furnishes and installs:

1. Conduit and conductors.
2. Water-tight hub.
3. Company listed 4-terminal meter socket (see Note 1 and sheets D-3 and D-5).
4. Metallic conduit shall be bonded to the meter socket.

Company furnishes and installs:

5. Watthour meter

Note:

1. Provide 4" clearance around meter from all foreign objects.
2. When supplied from a 1-phase, 3-wire, 120/240 volt grounded system or a 3-phase, 4-wire, 208Y/120 volt grounded radial system.
3. When supplied from a 3-phase, 3-wire, 240 volt grounded system.
4. For maintenance only.

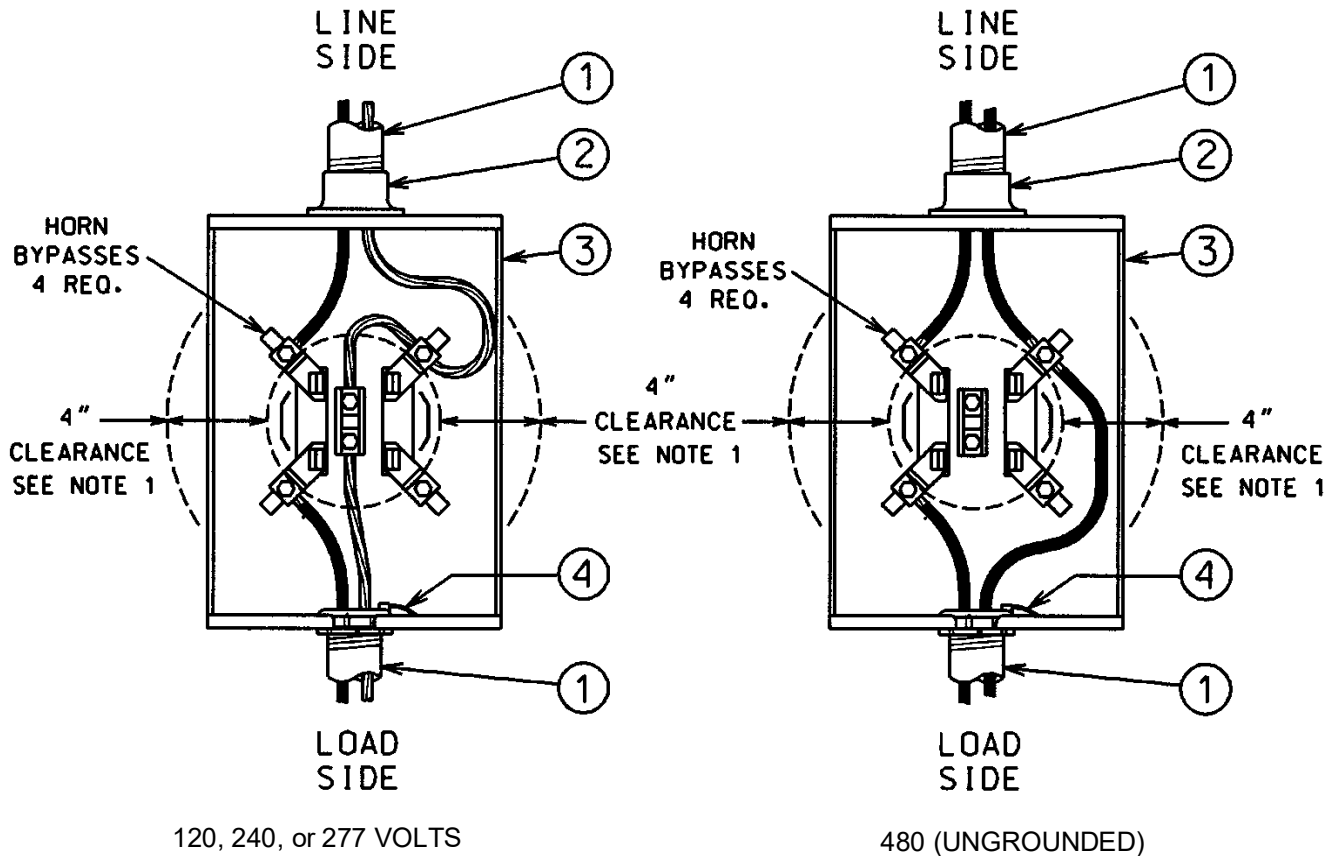

METER SOCKET WITH OVERHEAD SERVICE ENTRANCE

1Ø, 3-WIRE, 120/240 VOLTS, 0-320 AMPS

METERING SEQUENCE: METER-SWITCH-FUSE

Customer furnishes and installs:

1. Conduit and conductors.
2. Water-tight hub.
3. Company listed 4-terminal meter socket (see Note 1 and sheets D-3 and D-5).
4. Metallic conduit shall be bonded to the meter socket.

Company furnishes and installs:

5. Watthour meter.

Note:

1. Provide 4" clearance around meter from all foreign objects.

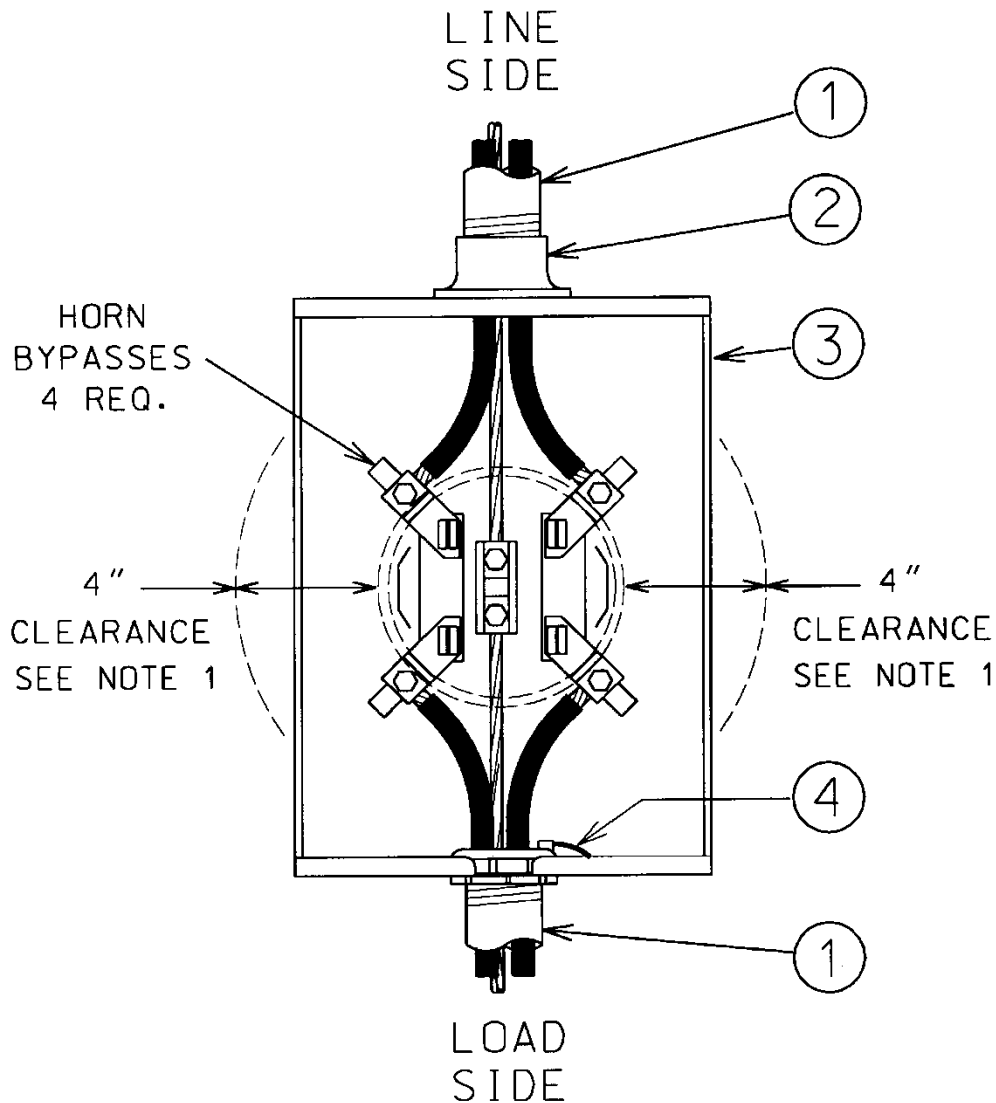

METER SOCKET WITH OVERHEAD SERVICE ENTRANCE

1Ø, 3-WIRE, 208Y/120 VOLTS, 0-100 AMPS

METERING SEQUENCE: METER-SWITCH-FUSE (SEE NOTE 3)

Customer furnishes and installs:

1. Conduit and conductors.
2. Water-tight hub.
3. Company listed 5-terminal meter socket (see Note 1 and sheet D-4).
4. Metallic conduit shall be bonded to the meter socket.
5. 5th terminal shall be in the 9 o'clock position (see Note 2).

Company furnishes and installs:

6. Watthour meter.

Notes:

1. Provide 4" clearance around meter from foreign objects.
2. If the potential tap from the neutral conductor to the 5th terminal is not supplied by the manufacturer, a #14 white insulated wire shall be used.
3. SW-F-M sequence may be required for indoor, 208Y/120 volt, downtown Milwaukee services.
4. Two phase wires and a neutral supplied from a 3-phase, 4-wire, 208Y/120 volt grounded system.

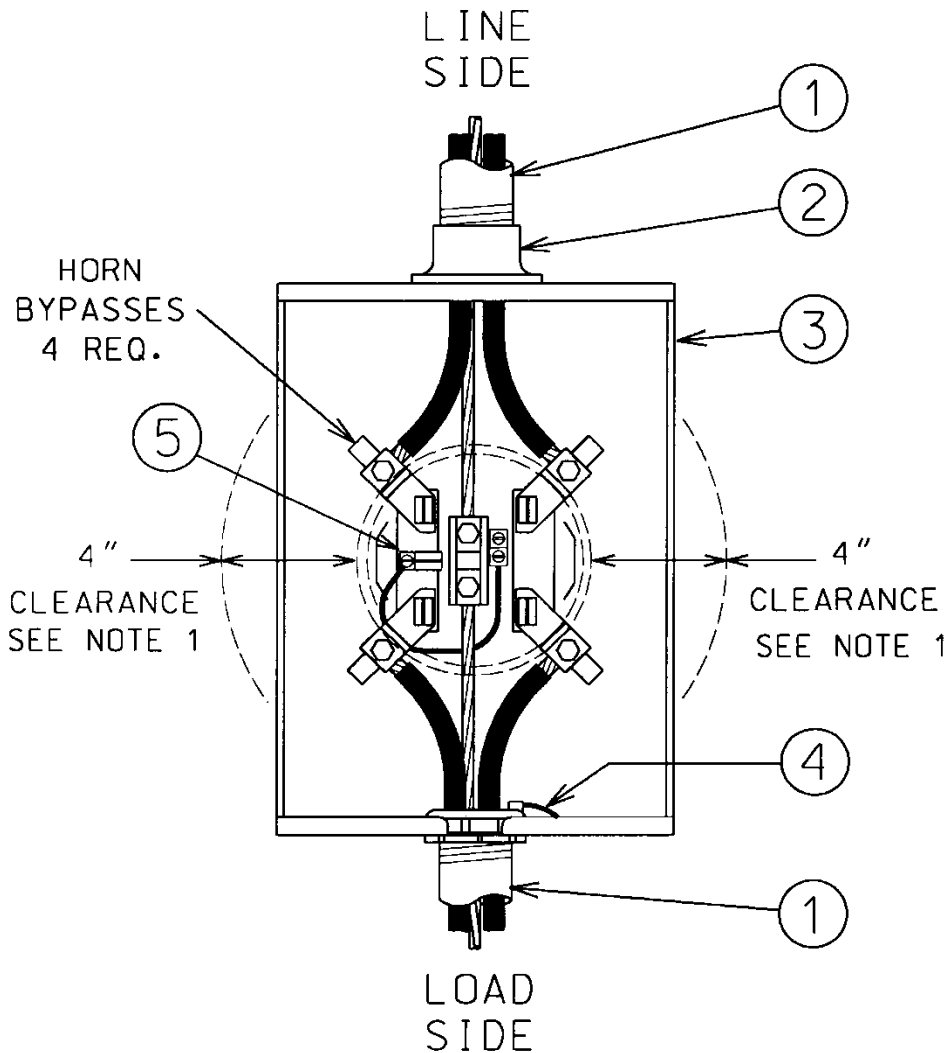

METER SOCKET WITH OVERHEAD SERVICE ENTRANCE

3Ø, 4-WIRE, 208Y/120 OR 480Y/277 VOLTS, 0-200 AMPS

METERING SEQUENCE: METER-SWITCH-FUSE (SEE NOTE 3)

Customer furnishes and installs:

1. Conduit and conductors.
2. Water-tight hub.
3. Company listed 7-terminal meter socket (see Note 1 and sheet D-4).
4. 7th terminal with potential tap (see Note 2).
5. Metallic conduit shall be bonded to the meter socket.

Company furnishes and installs:

6. Watthour meter.

Notes:

1. Provide 4" clearance around meter from foreign objects.
2. If the potential tap from the neutral conductor to the 7th terminal is not supplied by the manufacturer, a #14 white insulated wire shall be used.
3. SW-F-M sequence may be required for indoor, 208Y/120 volt, downtown Milwaukee services.
4. Two phase wires and a neutral supplied from a 3-phase, 4-wire, 208Y/120 volt grounded system.

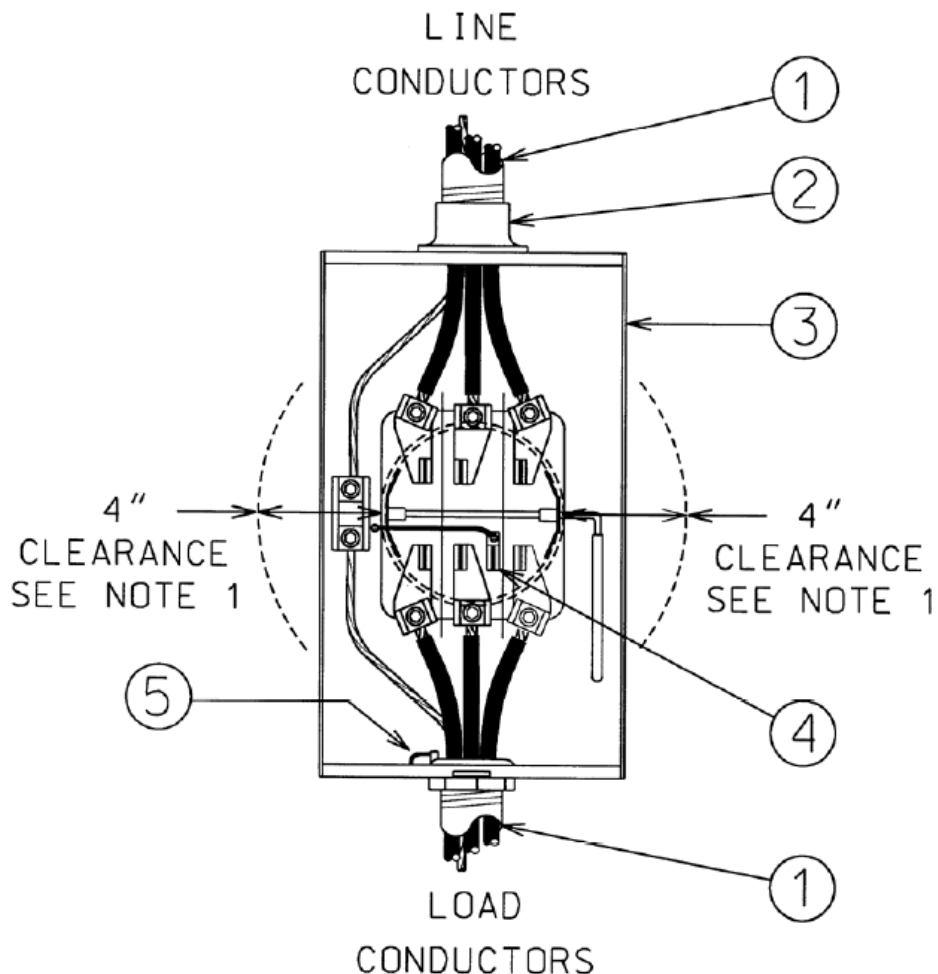

METER SOCKET FOR CUSTOMER OWNED STREETLIGHTING

1Ø, 3-WIRE, 240/480 VOLTS (GROUNDED), 0-200 AMPS

METERING SEQUENCE: METER-SWITCH-FUSE

Customer furnishes and installs:

1. Conduit and conductors.
2. Water-tight hubs.
3. Company listed 4-terminal meter socket (see Note 1 and sheet D-6).
4. Metallic conduit shall be bonded to the meter socket.

Company furnishes and installs:

5. Watthour meter.

Notes:

1. Provide 4" clearance around meter from all foreign objects.

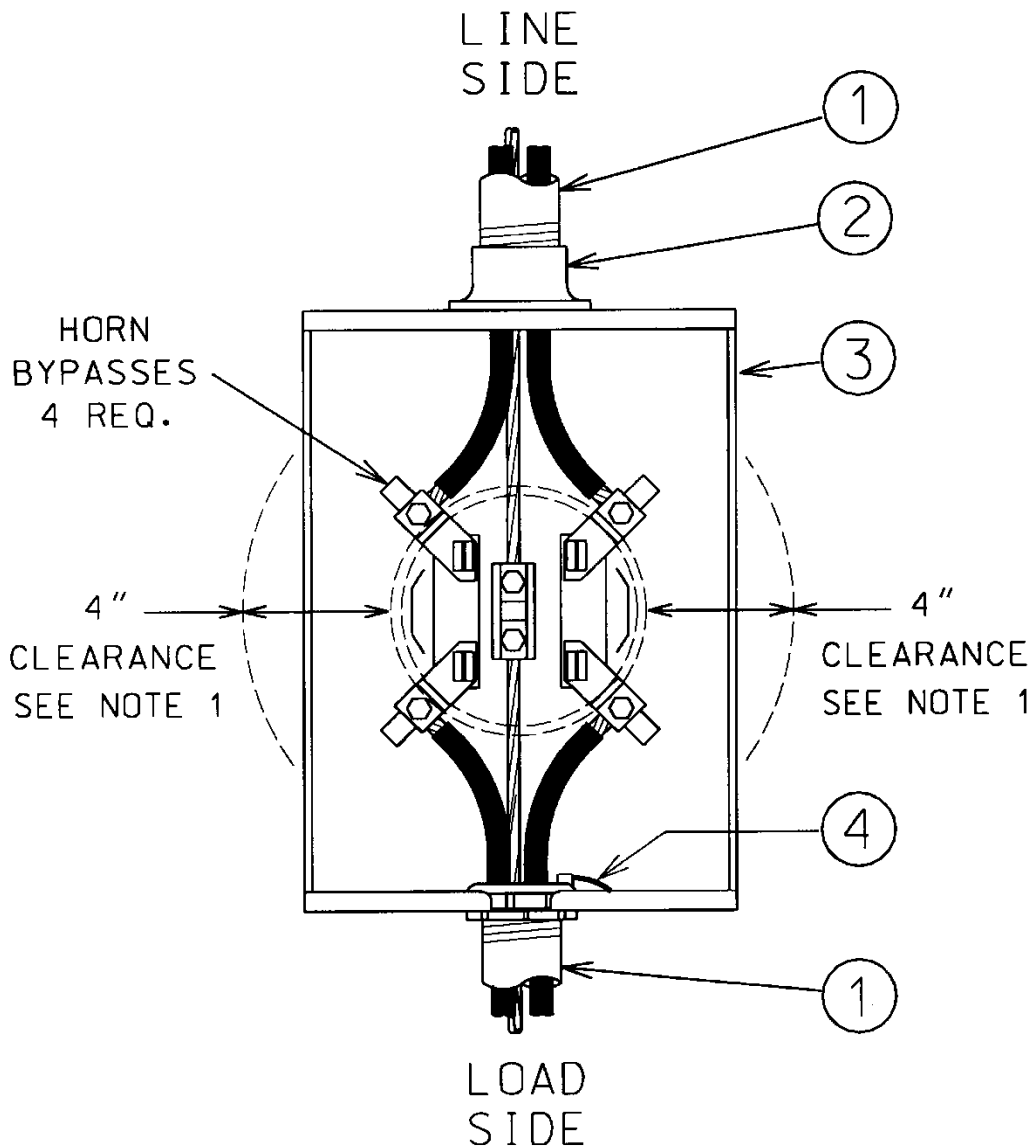

METER PEDESTAL WITH UNDERGROUND SERVICE LATERAL

1Ø, 2-WIRE, 120 VOLTS, 0-30 AMPS

1Ø, 2-WIRE, 480 VOLTS (UNGROUND), 0-100 AMPS (MAINTENANCE ONLY)

METERING SEQUENCE: METER-SWITCH-FUSE

Customer furnishes and installs:

1. Service entrance conduit and conductors (see Note 1).
2. Company listed 4-terminal meter pedestal (see Note 2 & sheets D-9 and D-10).
3. Metallic conduit shall be bonded to the meter pedestal.
4. Service entrance conductor, neutral.
5. Service entrance conductor, phase or hot wire.

Company furnishes and installs:

6. Service lateral.
7. Watthour meter (not shown).

Notes:

1. Service entrance conductors must exit the pedestal below the lowest live part and above grade.
2. Provide 4" clearance around meter from all foreign objects.
3. For use with 480 Volt, 1Ø, 2-wire service, the pedestal must be rated for 480 Volts or above.

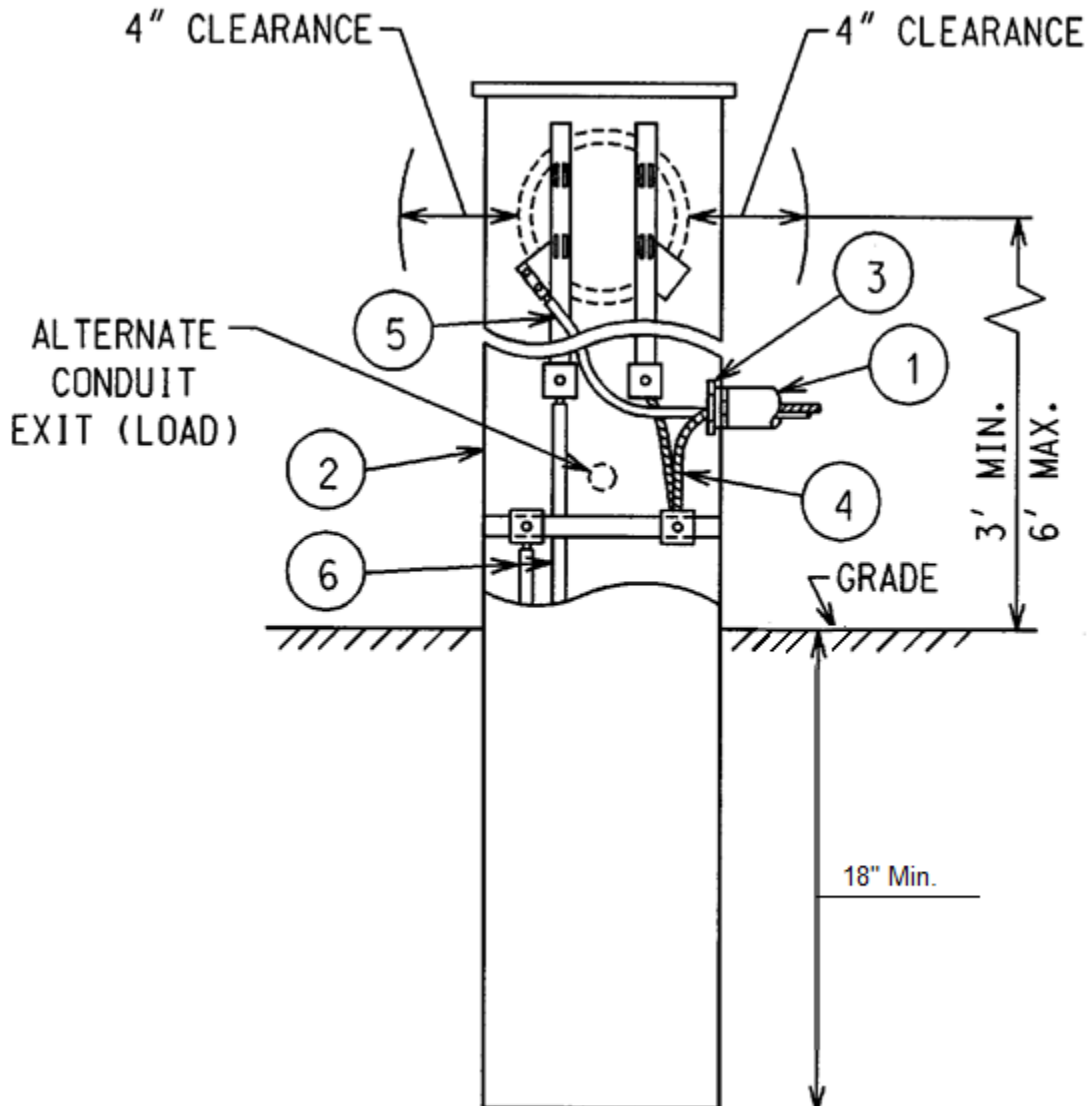

METER PEDESTAL WITH UNDERGROUND SERVICE LATERAL

1Ø, 3-WIRE, 120/240 OR 240/480 VOLTS, 0-200 AMPS

METERING SEQUENCE: METER-SWITCH-FUSE

Customer furnishes and installs:

1. Service entrance conduit and conductors (see Note 1).
2. Company listed 4-terminal meter pedestal (see Note 2 & sheets D-9 and D-10).
3. Metallic conduit shall be bonded to the meter pedestal.

Company furnishes and installs:

4. Service lateral.
5. Watthour meter (not shown).

Notes:

1. Service entrance conductors must exit the pedestal below the lowest live part and above grade.
2. Provide 4" clearance around meter from all foreign objects.
3. For use with 240/480 Volt, 1Ø, 3-wire service, the pedestal must be rated for 480 Volts or above.

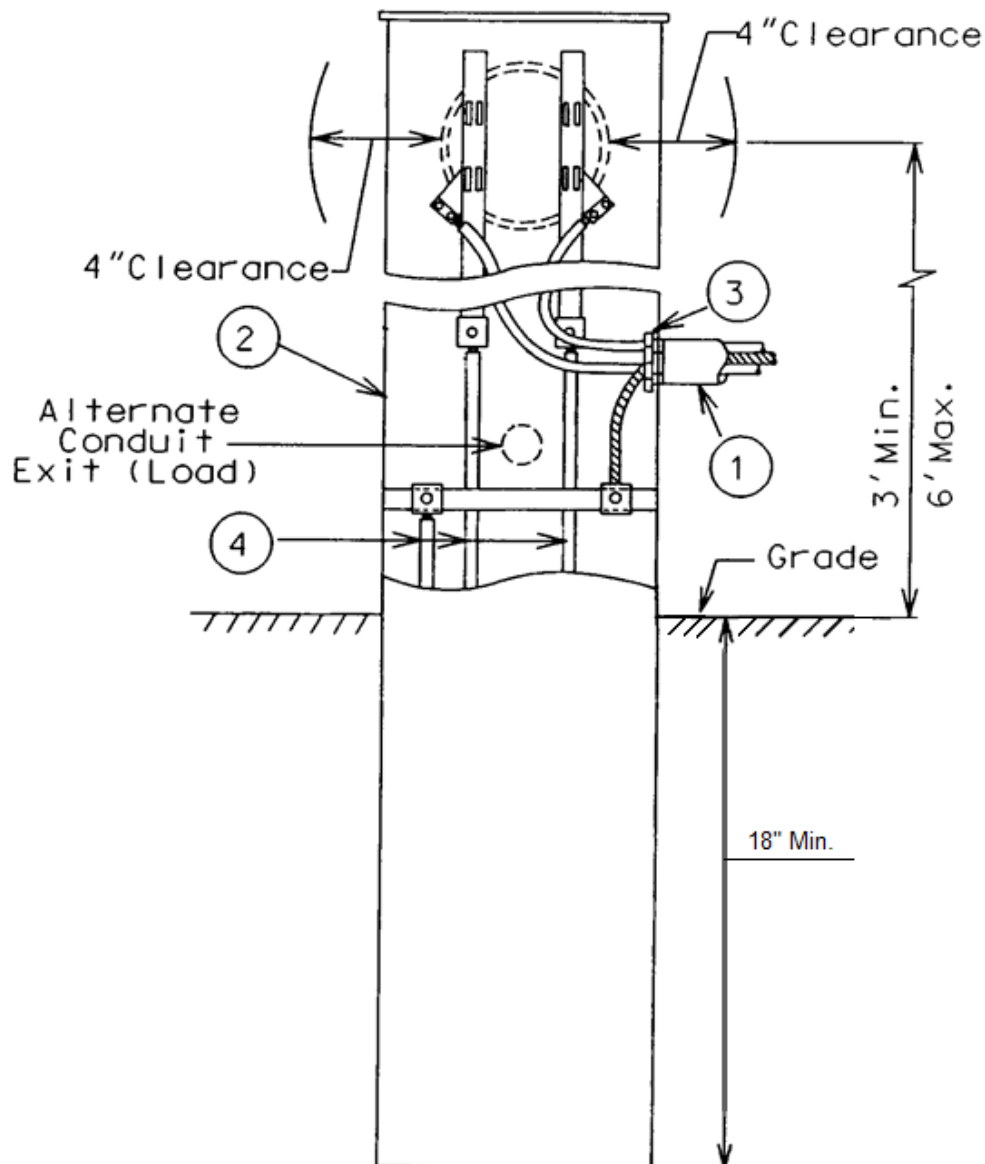

METER PEDESTAL WITH UNDERGROUND SERVICE LATERAL

1Ø, 3-WIRE, 120/240 VOLTS, 320 AMPS

METERING SEQUENCE: METER-SWITCH-FUSE

Customer furnishes and installs:

1. Company listed 4-terminal meter pedestal (see Note 1 & sheets D-9 and D-10).
2. Service entrance conduit and conductors (see Note 2).
3. Metallic conduit shall be bonded to the meter pedestal.

Company furnishes and installs:

4. Service lateral.
5. Watthour meter (not shown).

Notes:

1. Provide 4" clearance around meter from all foreign objects.
2. Service entrance conductors are allowed to leave as two circuits and must exit the pedestal below the lowest live part and above grade.
3. This equipment is rated at 320 Amps for continuous duty, which must not be exceeded.
4. Requires anti-inversion clip.

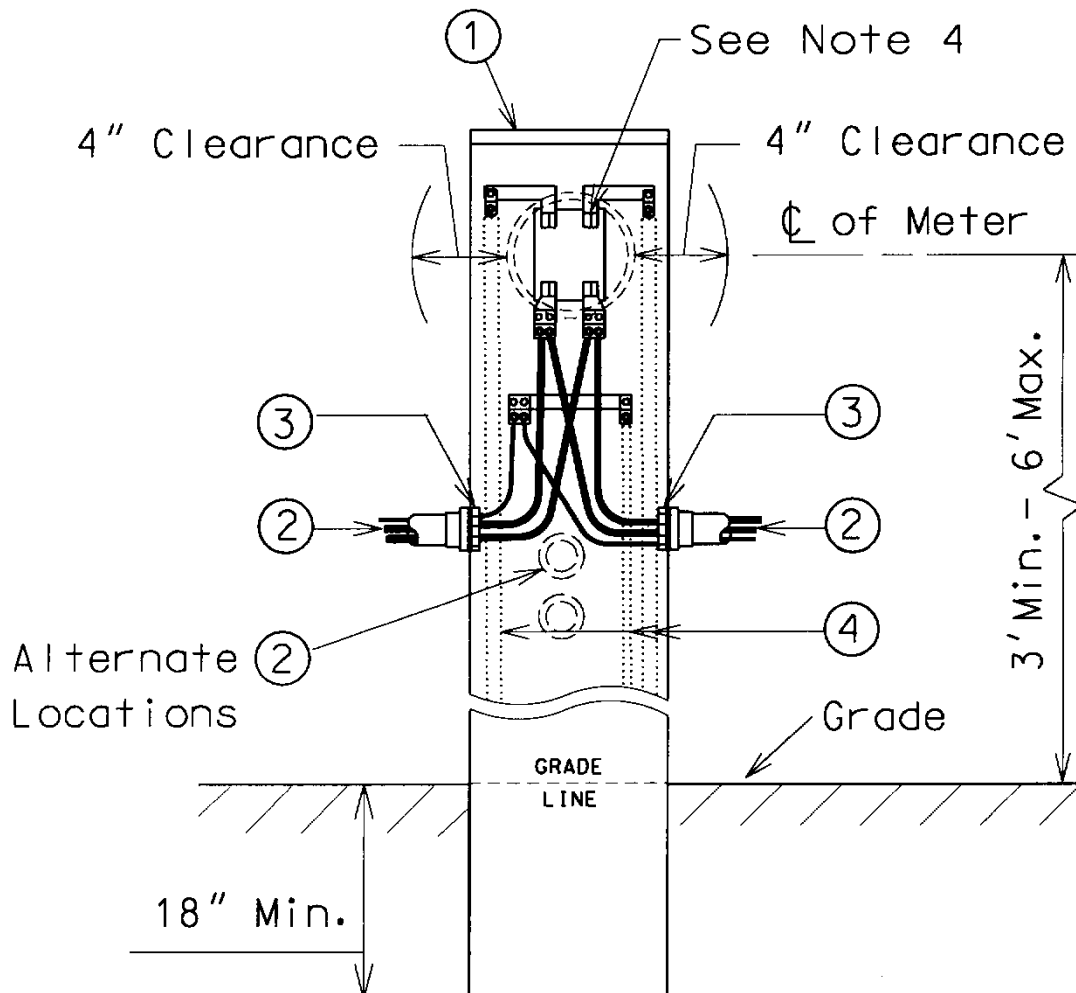

METER PEDESTAL WITH UNDERGROUND SERVICE LATERAL

1Ø, 3-WIRE, 208Y/120 VOLTS, 0-100 AMPS

METERING SEQUENCE: METER-SWITCH-FUSE

Customer furnishes and installs:

1. Service entrance conduit and conductors (see Note 1).
2. Company listed 5-terminal meter pedestal(see Note 2 & sheet D-10).
3. Metallic conduit shall be bonded to the meter pedestal.
4. 5th terminal shall be installed in the 9 o'clock position (see Note 3).

Company furnishes and installs:

5. Service lateral.
6. Watthour meter (not shown).

Notes:

1. Service entrance conductors must exit the pedestal below the lowest live part and above grade.
2. Provide 4" clearance around meter from all foreign objects.
3. If the potential tap from the neutral conductor to the 5th terminal is not provided by the manufacturer, it shall be a #14 white insulated wire for 208Y/120 Volts.
4. Two phase wires and a neutral supplied from a 3-phase, 4-wire, 208Y/120 volt grounded system.

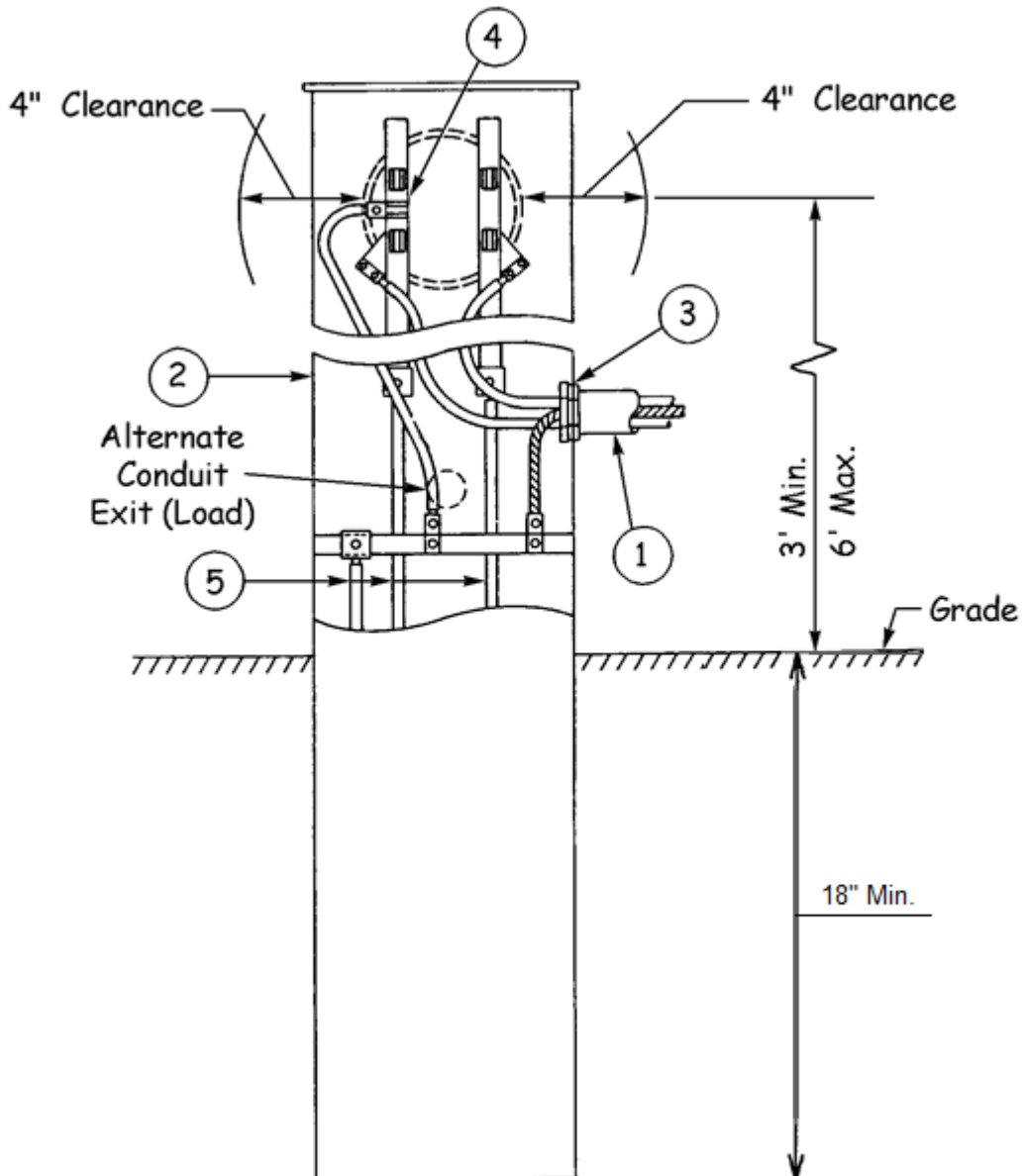

METER PEDESTAL WITH UNDERGROUND SERVICE LATERAL

3Ø, 4-WIRE, 208Y/120 OR 480Y/277 VOLTS, 0-200 AMPS

METERING SEQUENCE: METER-SWITCH-FUSE (SEE NOTE 5)

Customer furnishes and installs:

1. Service entrance conduit and conductors (see Note 1).
2. Company listed 7-terminal meter pedestal (see Notes 2, 3, & sheet D-10).
3. Metallic conduit shall be bonded to the meter pedestal.
4. 7th terminal with potential tap (see Note 4).

Company furnishes and installs:

5. Service lateral.
6. Watthour meter (not shown).

Notes:

1. Service entrance conductors must exit the pedestal below the lowest live part and above grade.
2. Provide 4" clearance around the meter from all foreign objects.
3. Pedestal extension kits are required with the pedestals approved on sheet D-10 for this type of installation.
4. If the potential tap from the neutral conductor to the 7th terminal is not provided by the manufacturer, it shall be a #14 white insulated wire.
5. SW-F-M sequence is required for indoor, 208Y/120 volt, downtown Milwaukee services.

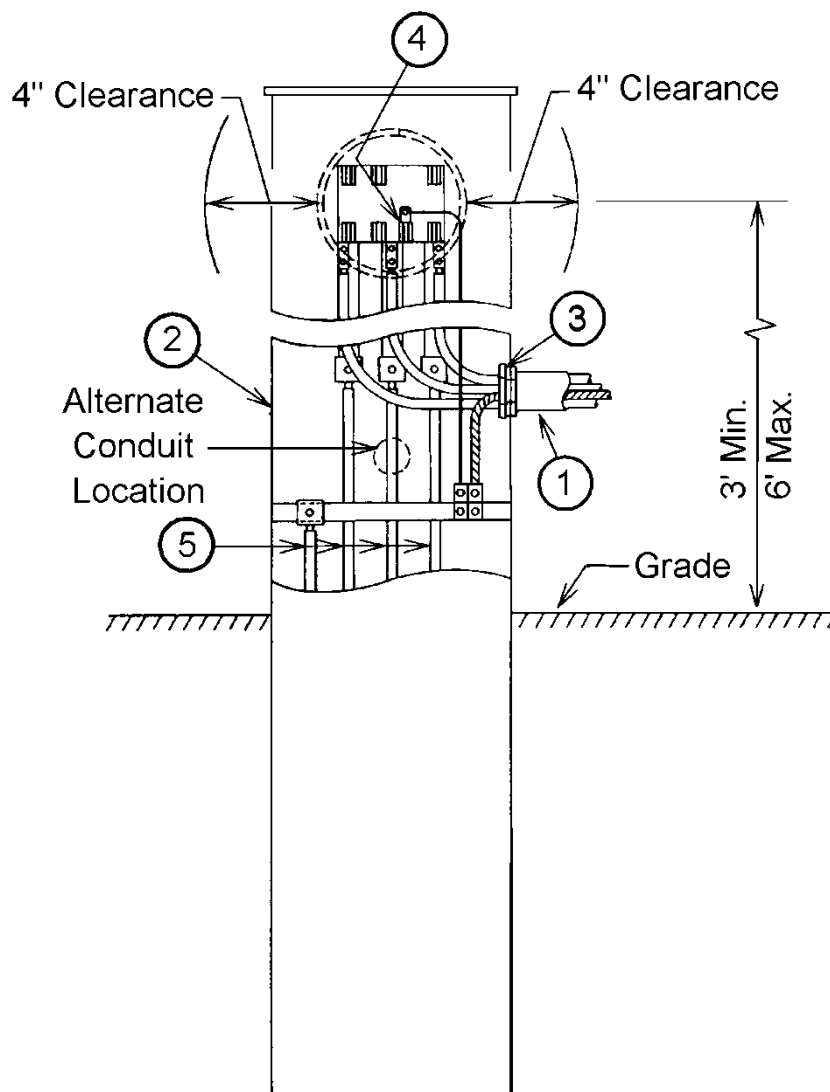

TRANSOCKET WITH OVERHEAD SERVICE ENTRANCE

1Ø, 3-WIRE, 120/240 VOLTS, 400-800 AMPS

ALL 3Ø VOLTAGES, 400-2000 AMPS

METERING SEQUENCE: METER-SWITCH-FUSE (SEE NOTE 3)

Obtain acceptance for 1Ø installations larger than 400 amps from the company.

Customer furnishes and installs:

1. Company listed transocket with transformer rated meter socket (see Note 1 and sheets D-14 & D-17).
2. Service entrance conduit and conductors.
3. Metallic conduit shall be bonded to the transocket.
4. Solid bar (see Note 2).

Company furnishes and installs:

5. Current transformers.
6. Watthour meter & wiring (not shown).

Notes:

1. A 6-terminal socket is required for a 1-phase, 3-wire service; and 8-terminal socket is required for a 3-phase, 3-wire service; a 13 terminal socket is required for a 3-phase, 4-wire service.
2. For 480 volt ungrounded applications, the center phase bar (required) shall be removable.
3. SW-F-M sequence is required for indoor, 208Y/120 volt, downtown Milwaukee services.

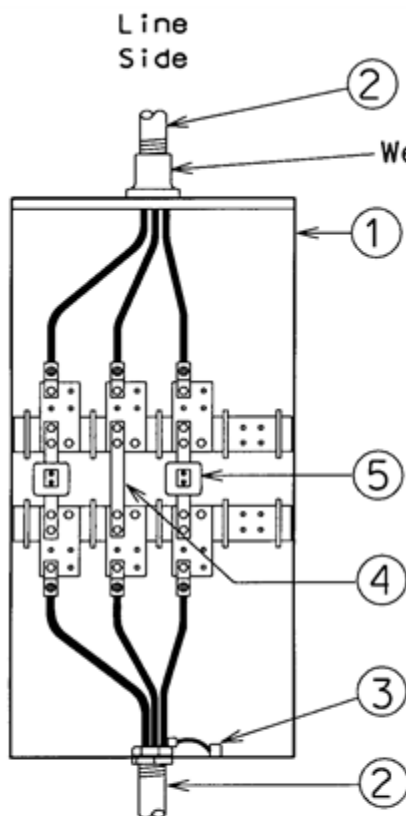

1Ø, 3 Wire
Cover Removed

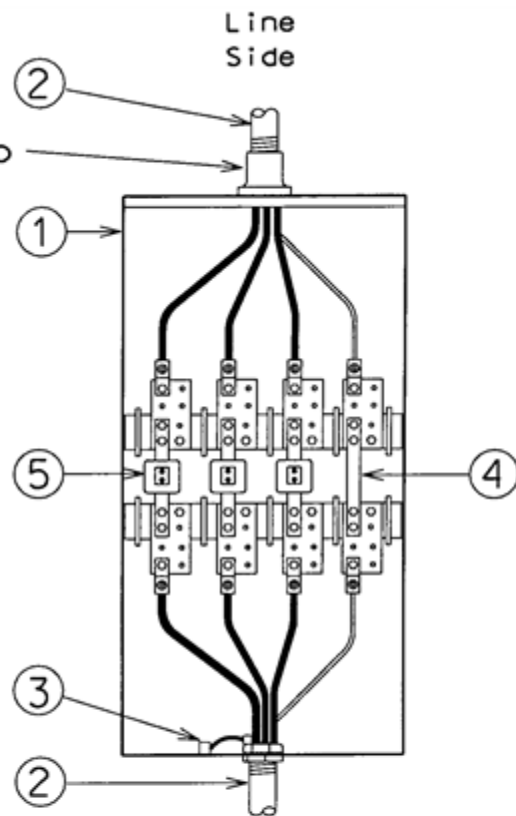

3Ø, 4 Wire
Cover Removed

TRANSOCKET WITH UNDERGROUND SERVICE ENTRANCE

1Ø, 3-WIRE, 120/240 VOLTS, 400-800 AMPS

ALL 3Ø VOLTAGES, 400-2000 AMPS

3Ø, 4-WIRE, 208Y/120 VOLTS OR 480Y/277 VOLTS, 400-4000 AMPS

METERING SEQUENCE: METER-SWITCH-FUSE (SEE NOTE 5)

Obtain acceptance for 1Ø installations larger than 400 amps from the company.

Customer furnishes and installs:

1. Company listed transocket with transformer rated meter socket (see Note 1 and sheets D-16 & D-17).
2. Service lateral conduit (800 A raceway shown).
3. Service entrance conduit and conductors.
4. Metallic conduit shall be bonded to the transocket.
5. Solid bar (see Note 2).

Company furnishes and installs:

6. Service lateral & lug type terminations (see Note 3).
7. Current transformers.
8. Watthour meter & wiring (not shown).

Notes:

1. A 6-terminal socket is required for a 1-phase, 3-wire service; and 8-terminal socket is required for a 3-phase, 3-wire service; a 13 terminal socket is required for a 3-phase, 4-wire service.
2. For 480 volt ungrounded applications, the center phase bar (required) shall be removable.
3. Lug landing pads shall be provided for 600+ A terminations. 400A terminations shall use set screw connectors.
4. The wiring gutter is for the service lateral (item 6) only. No other conductors are to pass through it. The transocket shown has the wiring space on the right; units with space on the left are also available.
5. SW-F-M sequence is required for indoor, 208Y/120 volt, downtown Milwaukee services.

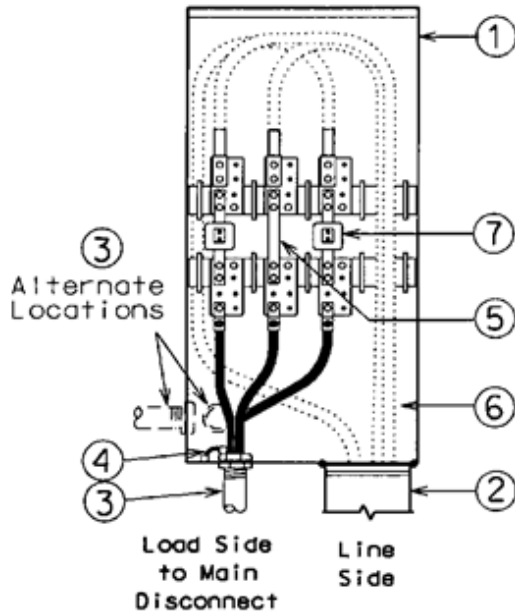

1Ø, 3 Wire
Cover Removed
(400 Ampere shown)

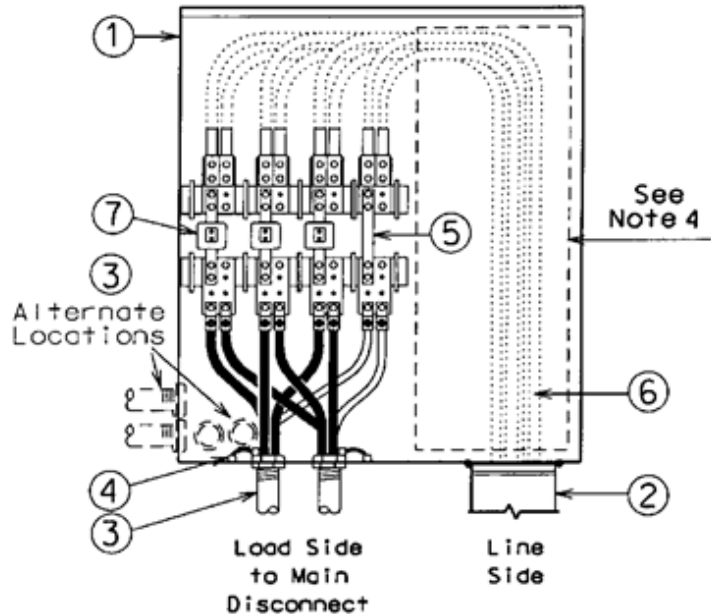

3Ø, 4 Wire
Cover Removed
(800 Ampere shown)

OUTDOOR CURRENT TRANSFORMER METERING WITH CUSTOMER DISCONNECT

1Ø, 3-WIRE, 120/240 VOLTS, 400-800 AMPS

ALL 3Ø VOLTAGES, 400-1200 AMPS

METERING SEQUENCE: METER-SWITCH-FUSE (SEE NOTE 5)

Obtain acceptance for 1Ø installations larger than 400 amps from the company.

Customer furnishes and installs:

1. Company listed combination metering transformer section disconnect with transformer rated meter socket (see Note 1 and sheets D-15 & D-17).
2. Service entrance conduit and conductors.
3. Raceway, 1600A maximum (see sheet D-16).
4. Raceway for service lateral (see Note 4).
5. Solid bar (see Note 2).
6. Metallic conduit shall be bonded to the transocket.

Company furnishes and installs:

7. Service lateral & lug type terminations (see Note 3).
8. Current transformers.
9. Watthour meter & wiring (not shown).

Notes:

1. A 6-terminal socket is required for a 1-phase, 3-wire service; and 8-terminal socket is required for a 3-phase, 3-wire service; a 13 terminal socket is required for a 3-phase, 4-wire service.
2. For 480 volt ungrounded applications, the center phase bar (required) shall be removable.
3. Lug landing pads shall be provided for 600+ A terminations. 400A terminations shall use set screw connectors.
4. The raceway (items 3 & 4) is for the service lateral (item 7) only. No other conductors are to pass through it. The transocket shown has the wiring space on the right; units with space on the left are also available.
5. SW-F-M sequence is required for indoor, 208Y/120 volt, downtown Milwaukee services.

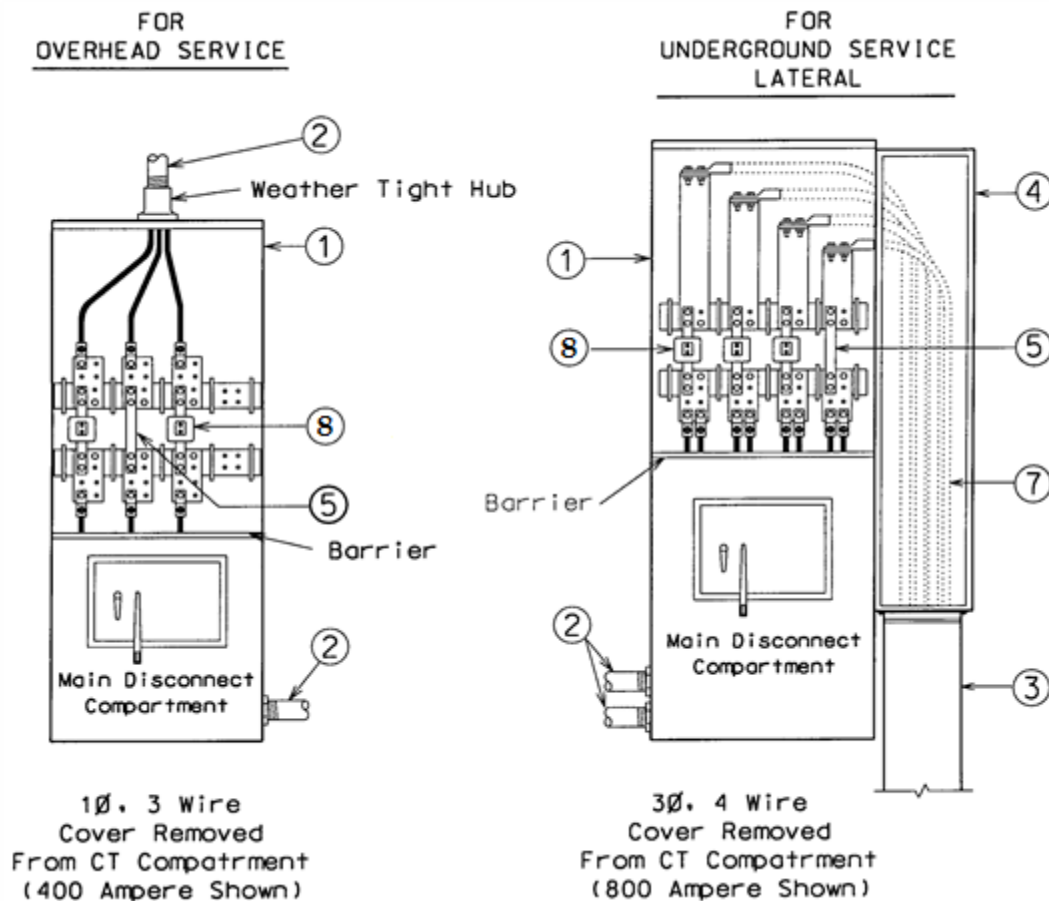

METER STACK SOCKET BREAKER INSTALLATION

ALL 1Ø, 3-WIRE VOLTAGES, 0-1600 AMPS

ALL 3Ø VOLTAGES, 0-2000 AMPS

METERING SEQUENCE: METER-SWITCH-FUSE (SEE NOTE 14)

Customer furnishes and installs:

1. Company listed termination compartment, breaker/disconnect, switch/fuse combination (see sheet D-21).
2. Company listed meter stacks (see Notes 1-3 and sheets D-11 through D-14).
3. Raceway, 1600A maximum (see sheet D-16).
4. Service lateral conduit, 4" (rigid galvanized or IMC if used outdoors).
5. Spacer (see Note 1).
6. Label identifying the individual unit served by the meter position (see Note 5).
7. Company listed transocket with transformer rated meter socket (see sheets D-16 & D-17)

Company furnishes and installs:

8. Watthour meters.
9. Service lateral

Notes:

1. 4" of clearance around meter is required.
2. Where the termination/switch/fuse compartment or switch handles have less than the 4" clearance, a spacer is required (Item 5).
3. All panels shall be removable for inspection or wiring. Each meter socket shall be individually sealable.
4. Before ordering and installing meter stacks, verify that the stack will meet the minimum and maximum meter height requirements when installed.
5. SW-F-M sequence is required for indoor, 208Y/120 volt, downtown Milwaukee services.
6. Each meter position shall be marked on the outside of the socket or by the breaker (if available) with the address of the unit served (see Note 7 on M-2). If the marking is on the outside of the removable cover, it shall also be marked on the inside of the meter socket in a visible location. This marking shall also be placed on the corresponding distribution panel(s). The marking shall be a permanent label with 1/2" block letters and may consist of individual self-stick letters or numbers, suitable for the location so as to be considered permanent.
7. Multi-metered installations shall be installed so as to balance the load on the service.

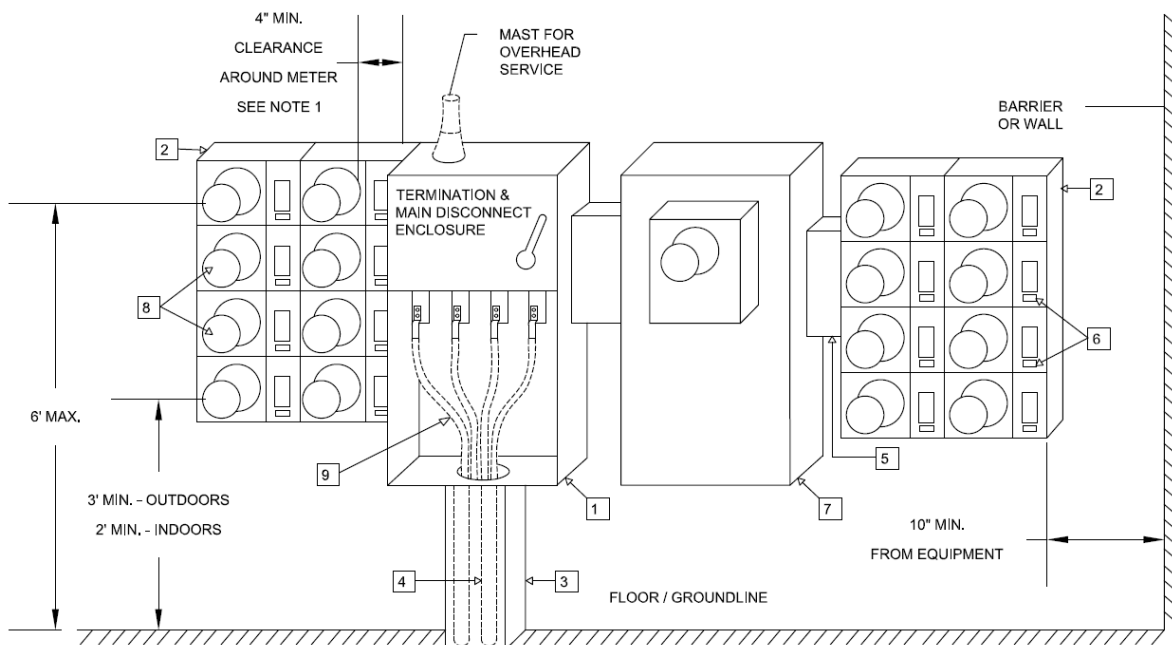

CURRENT TRANSFORMER METERING IN FREE STANDING SWITCHGEAR

1Ø, 3-WIRE, 120/240 VOLTS, 400-800 AMPS

ALL 3Ø VOLTAGES, 400-4000 AMPS

METERING SEQUENCE: METER-SWITCH-FUSE (SEE NOTE 14)

Customer furnishes and installs:

1. Company listed transformer rated meter socket (see Note 1 and Sheet D-17).
2. Conduit and Pull String (see Note 2).
3. Current transformer (CT) compartment as part of the main switchboard (see Notes 3 to 12).
4. Main breaker compartment.
5. Distribution equipment.
6. Service entrances (see Overhead or Underground sections for installation details).
7. Alternate location of the line and load side bus bar.
8. Alternate location for insulating barrier when alternate load bus is used.

Company furnishes and installs:

9. Meter test switch (not shown).
10. Watthour meter (not shown).
11. Meter wire from the secondary side of CTs to meter (not shown).
12. CTs and necessary mounting bolts (not shown).

Notes:

1. Meter socket shall be installed within sight of or attached to the CT compartment with the following limitations:
 - a. Meter must be installed in a suitable location as outlined in the preceding General Requirements.
 - b. Meter conduit shall be run exposed where practicable.
 - c. Consult the company if the distance between the CT compartment and meter location exceeds 40'.
2. 1-1/4" galvanized rigid, galvanized intermediate, or, if indoors, rigid nonmetallic Schedule 40 PVC per NEMA Standard TC-2, to extend between the CT compartment and meter cabinet. If nonmetallic conduit is used, a #12 copper conductor or equivalent must be installed in the conduit to maintain continuity of equipment ground. This conductor must be bare or green covered with one or more yellow stripes. **Customer to terminate the conductor on meter enclosure and grounding point in switchgear.**
3. The CT compartment shall be completely enclosed; barriers between compartments shall be rigidly supported.
4. No transition bus is allowed within the CT compartment with the bus configuration shown.
5. Front of CT compartment shall be enclosed using one of the following methods:
 - a. Double hinged door with sealable hasp and double bolt type latch (preferred).
 - b. Single hinged door with sealable hasp and double bolt type latch.
6. The following live part clearances must be maintained: 2" phase-to-phase, 1" phase-to-ground.
7. The CT bar will be drilled to conform to EEI Pub. MSJ-11.
8. For 1-phase and 3-phase services 1200 amps or less, provide a set screw lug for a #12 gauge wire in the neutral bar for a potential tap. For 3-phase services over 1200 amps, provide a set screw lug for a #12 gauge wire in the bus bars of each phase and the neutral for the potential tap as shown in the bus bar drilling detail.
9. Bus supports shall have a minimum separation of 15" and shall consist of an insulating material such as Benelex. or equivalent, or porcelain insulators mounted on a steel channel.
10. Neutral bus must either run through or be extended back into the CT cabinet so that it is accessible for the potential tap. Working clearance between neutral bus and any live bus in the vicinity of the CT mounting must be 6" minimum. Neutral bus must not be located closer to the front of the enclosure than any live bus.
11. The compartment detail shown is for use with a 3-phase, 4-wire system. For 3-wire systems, the center phase bar is to be continuous and the neutral bar is to be omitted.
12. For services less than 1200 amps, refer to Sheet D-17 for approved CT compartments.
13. **Send a copy of drawings of the switchgear termination and metering compartments to the local We Energies job representative for acceptance prior to any construction.**
14. SW-F-M sequence is required for indoor, 208Y/120 volt, downtown Milwaukee services.

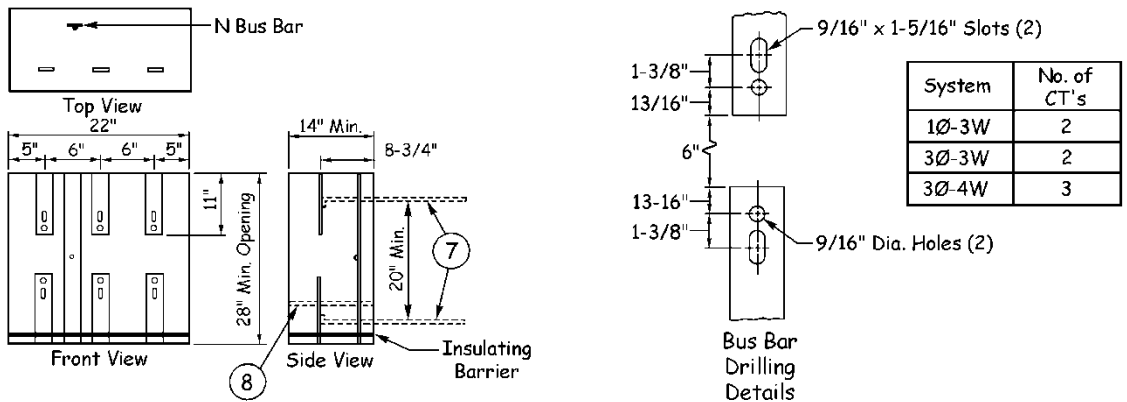
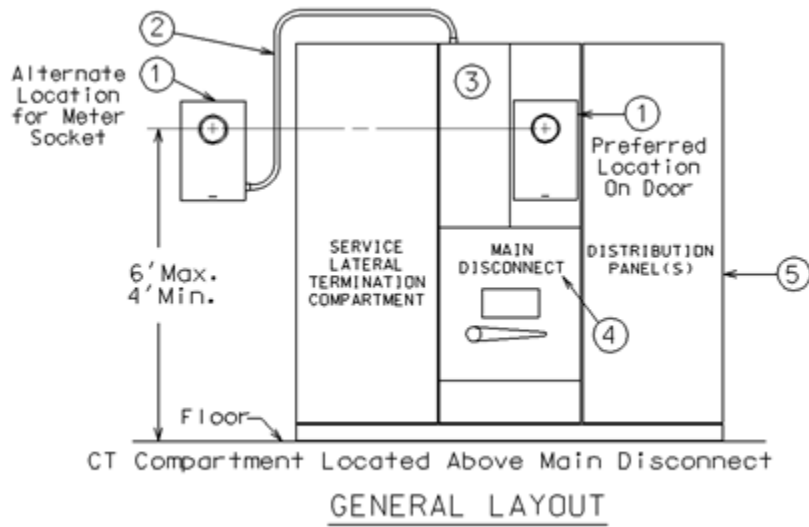

**1-PHASE, 120/240 VOLTS, 400-800 AMPERES
ALL 3-PHASE VOLTAGES, 400-1200 AMPERES**

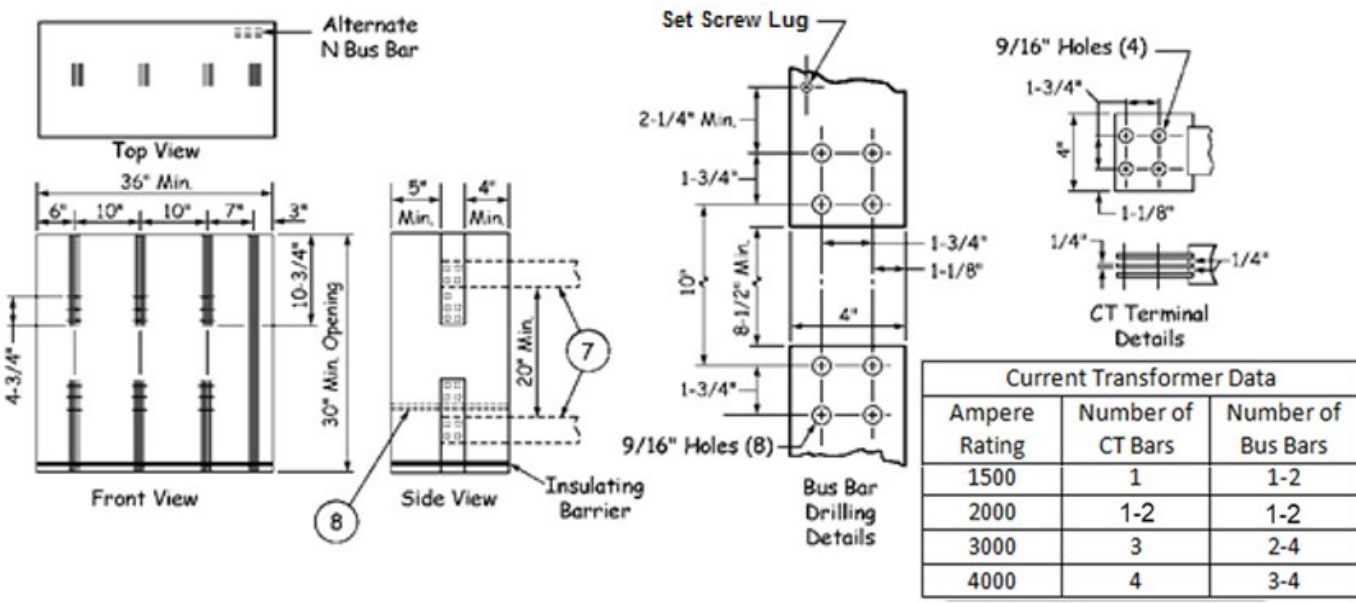

ALL 3-PHASE VOLTAGES, Over 1200 AMPERES

MODULAR METERING IN FREESTANDING SWITCHGEAR

1Ø, 3-WIRE, 120/240 OR 208Y/120 VOLTS, 0-200 AMPS PER METER

ALL 3Ø VOLTAGES, 0-200 AMPS PER METER

Obtain acceptance from the company.

Customer furnishes and installs:

1. Provisions for sealing (see Note 1).
2. Sealable cover. Double covers must be equipped with handles.
3. Benelex or polyester barrier (see Note 2).
4. Main disconnect when required (see Note 3).
5. Individual tenant disconnects.
6. Load conductor raceway.
7. Modular meter units (see Notes 4-7 and sheet D-14).

Company furnishes and installs:

8. Watthour meters.

Notes:

1. All covers which could expose unmetred bus shall have provisions for sealing.
2. All load raceways and lugs for connection of load conductors shall be separated by barriers from the meter area and from unmetred bus.
3. This device as shown is not suitable for the direct termination of Company service conductors. See Overhead or Underground sections of the manual for the appropriate termination methods.
4. For a 3-phase, 3-wire, 480 volt meter socket, there must be a center phase disconnecting link.
5. Provide 4" clearance around meter from all foreign objects.
6. The meter disconnect combination may consist of a preassembled module designed to be inserted into a bused enclosure.
7. Each meter position shall be marked on the outside of the socket or by the breaker (if available) with the address of the unit served (see Note 7 on M-2). If the marking is on the outside of the removable cover, it shall also be marked on the inside of the meter socket in a visible location. This marking shall also be placed on the corresponding distribution panel(s). The marking shall be permanent label with ½" block letters and may consist of individual self-stick letters or numbers, suitable for the location so as to be considered permanent.

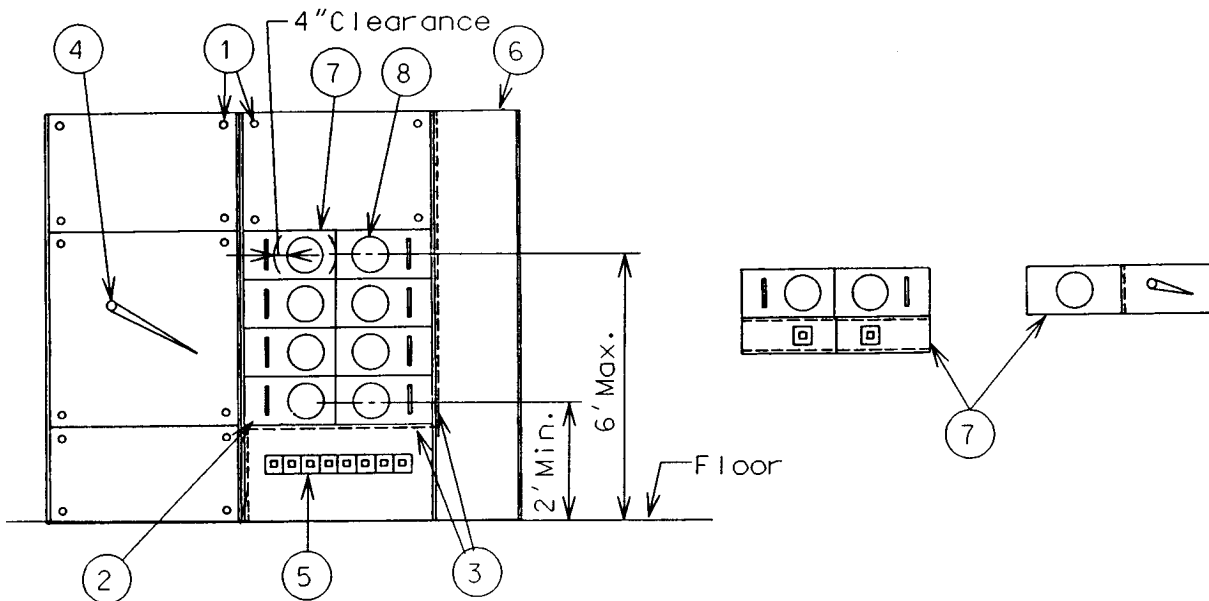

FULLY ASSEMBLED METERING SWITCHBOARD

MAINTENANCE ONLY

OH METER SOCKET 3Ø, 3-WIRE, 240 OR 480 VOLTS (UNGROUND), 0-200 AMPS

METERING SEQUENCE: METER-SWITCH-FUSE

Customer furnishes and installs:

1. Company listed 5-terminal meter socket with center phase sliding link disconnect (See Note 1 and sheet D-4).
2. Conduit and service entrance conductors.
3. Water-tight hub.
4. Metallic conduit shall be bonded to the meter socket.
5. 5th terminal shall be in the 6 o'clock position (See Note 2).

Company furnishes and installs:

6. Watthour meter.

Notes:

1. Provide 4" clearance around meter from all foreign objects.
2. If the potential tap from the neutral conductor to the 5th terminal is not supplied by the manufacturer, a #14 black insulated wire shall be used.

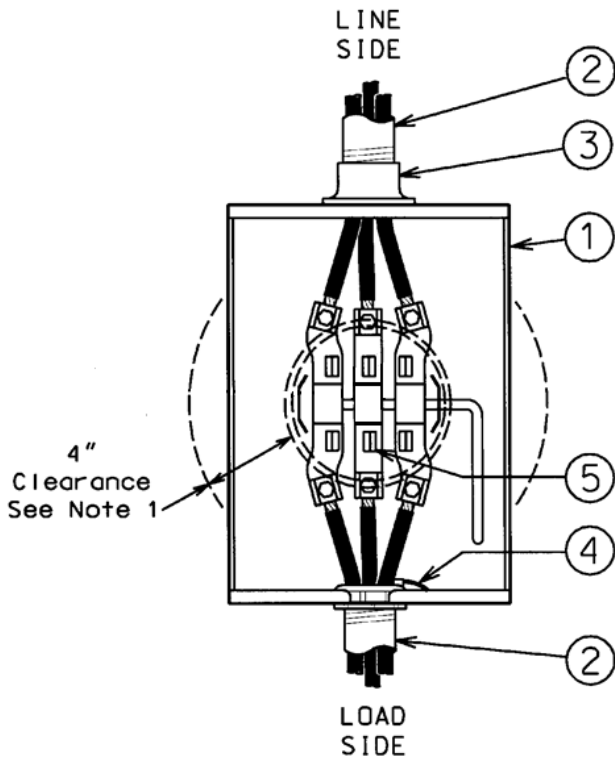

3Ø, 3-Wire, 240 Volts

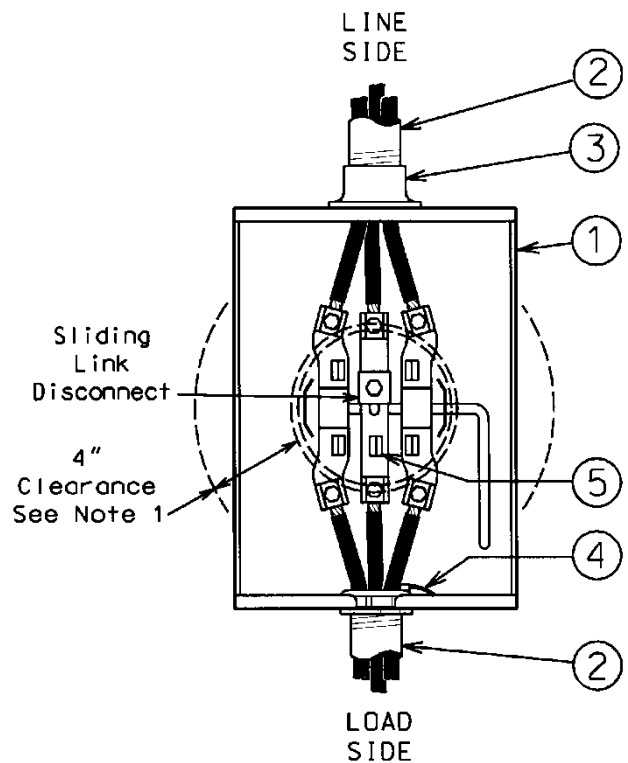

3Ø, 3-Wire, 480 Volts
(Ungrounded)

MAINTENANCE ONLY

UG METER SOCKET 1Ø, 3-WIRE, 120/240 VOLTS, 0-200 AMPS

METERING SEQUENCE: METER-SWITCH-FUSE

Obtain acceptance for 1Ø installations from the Company.

Customer furnishes and installs:

1. Service entrance conduit and conductors (see Note 1).
2. Company listed 4-terminal meter socket (see Note 2).
3. Service lateral conduit.
4. Metallic conduit shall be bonded to the meter socket.

Company furnishes and installs:

5. Service lateral.
6. Watthour meter (not shown).

Notes:

1. For a 120 volt, 2-wire service, the service entrance conductors consist of the neutral conductor and one of the phase conductors.
2. Provide 4" clearance around meter from all foreign objects.
3. The multi-position sockets listed on page D-7 can be used for new construction provided the cable raceway is used. Service lateral conduit shall not be used for new construction.
4. If meter socket needs to be replaced for any reason, an approved meter pedestal shall be used instead.

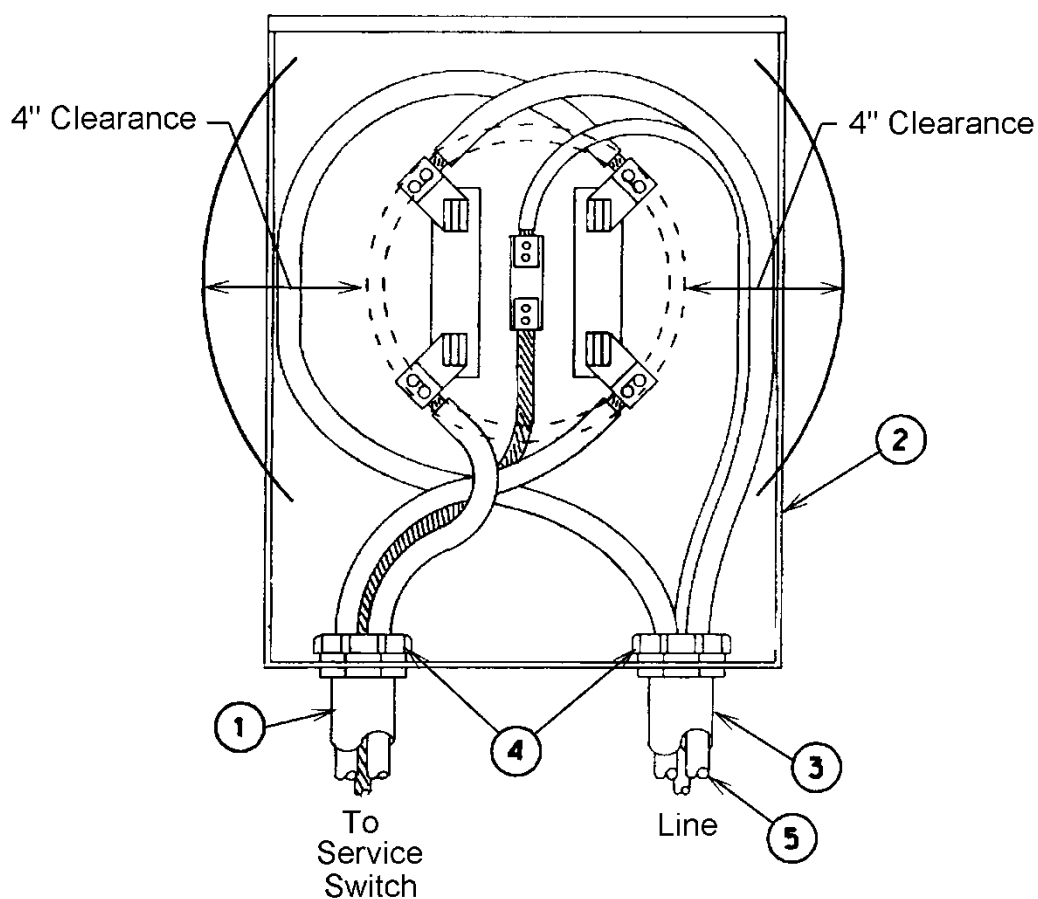

MAINTENANCE ONLY

UG METER SOCKET 1Ø, 3-WIRE, 208Y/120 VOLTS, 0-100 AMPS UG METER SOCKET 3Ø, 3-WIRE, 240 VOLTS OR 480 VOLTS (UNGROUND), 0-200 AMPS

METERING SEQUENCE: METER-SWITCH-FUSE (SEE NOTE 3)

Customer furnishes and installs:

1. Company listed 5-terminal meter socket (see Note 1).
2. Service entrance conduit and conductors.
3. Service lateral conduit.
4. 5th terminal (see Note 2).
5. Metallic conduit shall be bonded to the meter socket.

Company furnishes and installs:

6. Service lateral.
7. Watthour meter (not shown).

Notes:

1. Provide 4" clearance around meter from all foreign objects.
2. For 1-phase, 208Y/120 volt and 3-phase, 240 volt, the 5th terminal shall be in the 9 o'clock position. If the potential tap from the 5th terminal to the grounded conductor is not provided by the manufacturer, it shall be a #14 white insulated wire. For 480 volt, the 5th terminal shall be in the 6 o'clock position. If the potential tap from the 5th terminal to the center phase conductor is not provided by the manufacturer, it shall be a #14 black insulated wire.
3. SW-F-M sequence is required for indoor, 208Y/120 volt, downtown Milwaukee services.
4. Two phase wires and a neutral supplied from a 3-phase, 4-wire, 208Y/120 volt grounded system.
5. If meter socket needs to be replaced for any reason, an approved meter pedestal shall be used instead (except for downtown Milwaukee services).

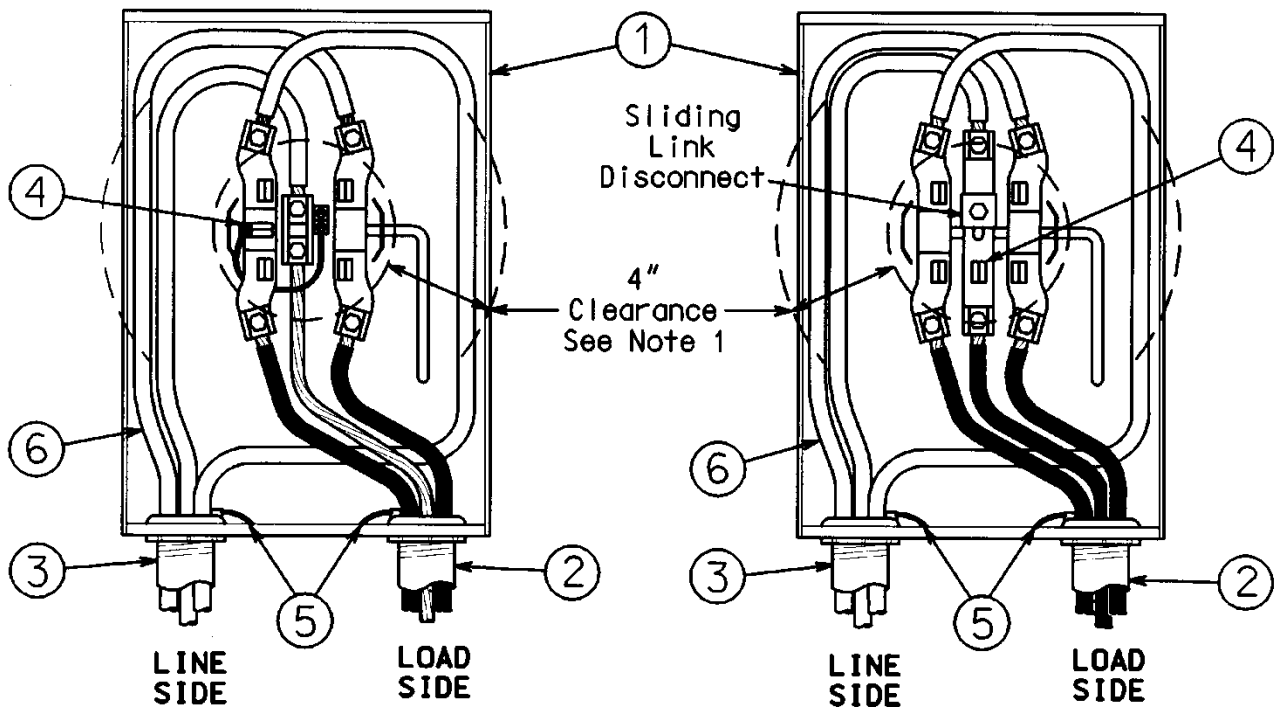

MAINTENANCE ONLY

UG METER SOCKET 3Ø, 4-WIRE, 208Y/120 OR 480Y/277 VOLTS, 0-200 AMPS

METERING SEQUENCE: METER-SWITCH-FUSE (SEE NOTE 3)

Customer furnishes and installs:

1. Service entrance conduit and conductors.
2. Company listed 7-terminal meter socket (see Note 1).
3. 7th terminal with potential tap (see Note 2).
4. Service lateral conduit.
5. Metallic conduit shall be bonded to the meter socket.

Company furnishes and installs:

6. Service lateral.
7. Watthour meter (not shown).

Notes:

1. Provide 4" clearance around meter from all foreign objects.
2. If the potential tap from the 7th terminal to the neutral conductor is not provided by the manufacturer, it shall be a #14 white insulated wire.
3. SW-F-M sequence is required for indoor, 208Y/120 volt, downtown Milwaukee services.
4. If meter socket needs to be replaced for any reason, an approved meter pedestal shall be used instead (except for downtown Milwaukee services).

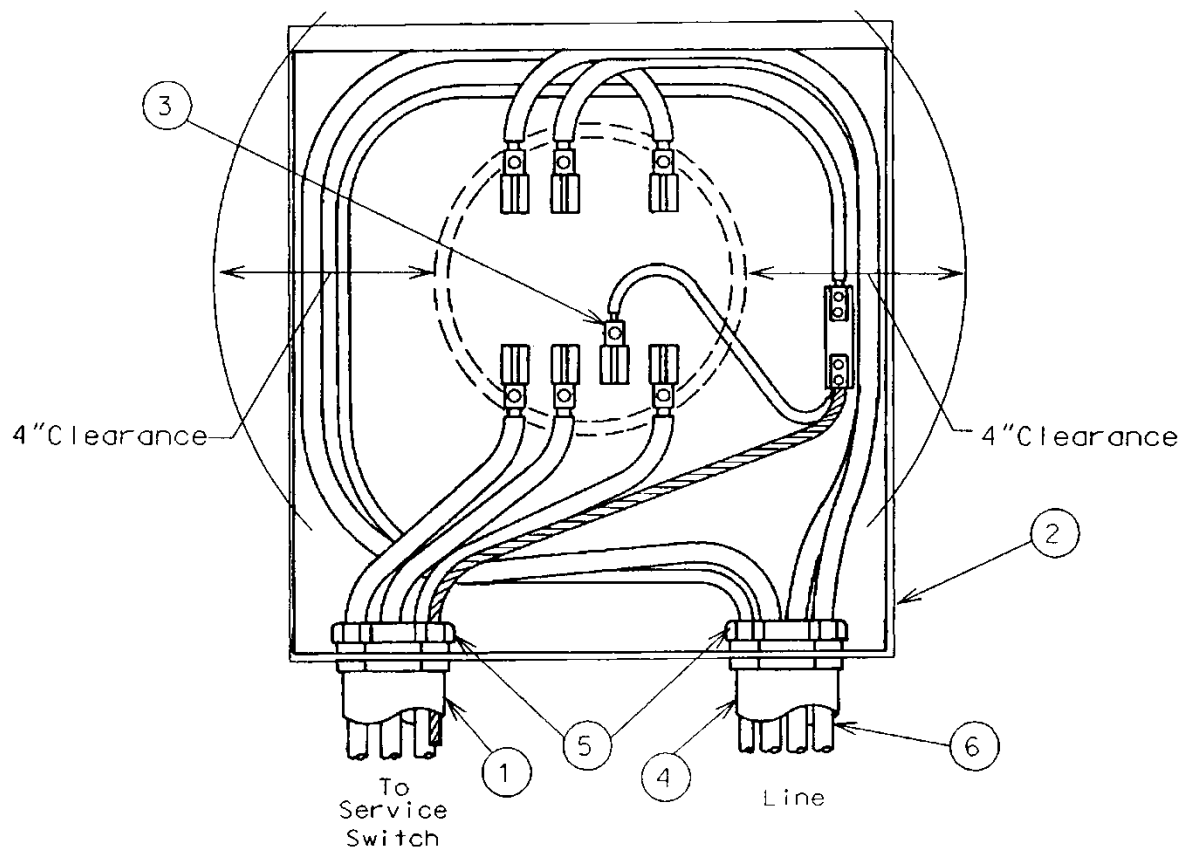

MAINTENANCE ONLY

UG METER PEDESTAL 3Ø, 3-WIRE, 240 OR 480 VOLTS (UNGROUND), 0-200 AMPS

METERING SEQUENCE: METER-SWITCH-FUSE

Customer furnishes and installs:

1. Service entrance conduit and conductors (see Note 1).
2. Company listed 5-terminal meter pedestal(see Note 2 & sheet D-10).
3. Metallic conduit shall be bonded to the meter pedestal.
4. 5th terminal shall be installed in the 6 o'clock position (see Note 4).

Company furnishes and installs:

5. Service lateral.
6. Watthour meter (not shown).

Notes:

1. Service entrance conductors must exit the pedestal below the lowest live part and above grade.
2. Provide 4" clearance around meter from all foreign objects.
3. If the potential tap from the neutral conductor to the 5th terminal is not provided by the manufacturer, it shall be a #14 black insulated wire for 240 or 480 Volts.
4. For 480 Volts, remove the B-phase grounding strap if present (see D-10, Note 11).

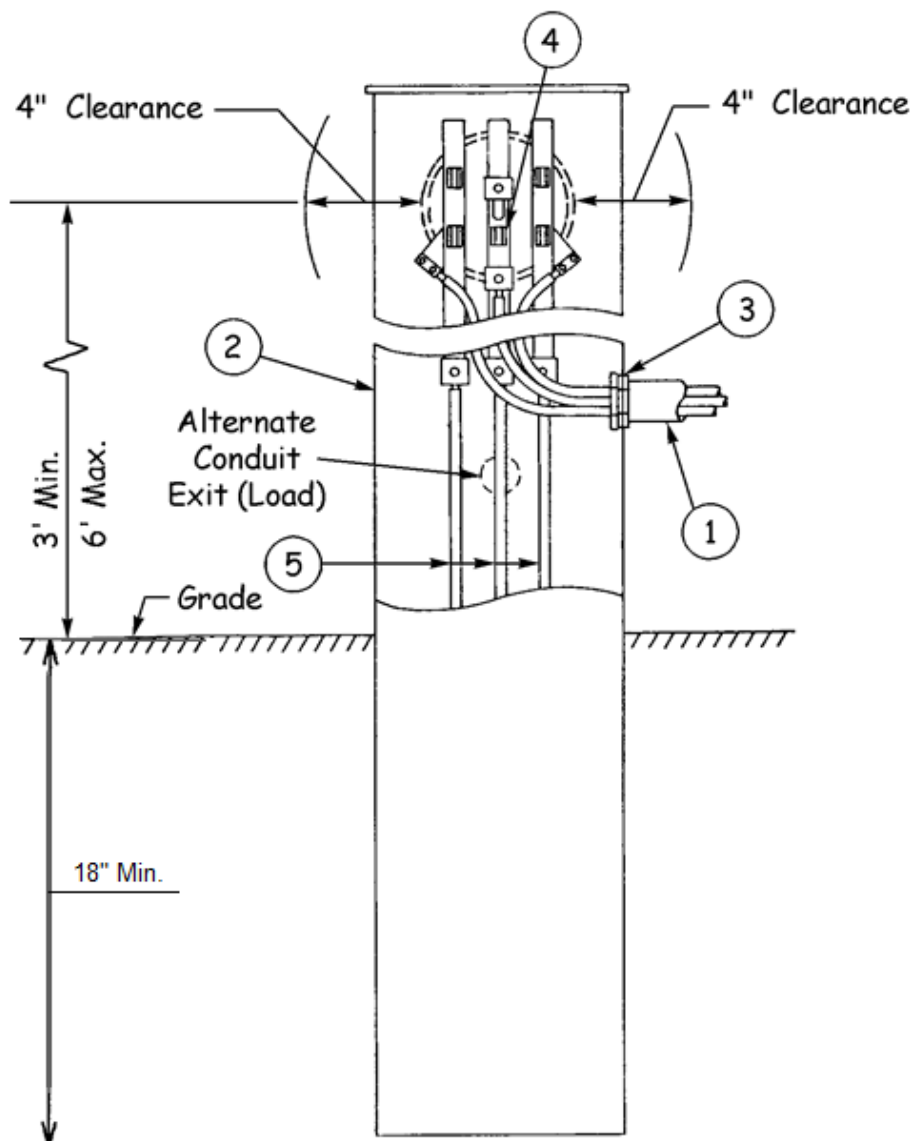

APPENDIX

CHOOSING THE PROPER METER SOCKET

In the Metering Devices book (Book 2 Section D), meter sockets are listed by the number of terminals. The intent of this article is to help the installer verify that the correct meter socket is installed. The type of meter socket is determined by the voltage, number of conductors, if the service is 1-phase or 3-phase, and the size of the service.

Types of Meters

Meters can be broken into two types: Self Contained and Transformer Rated.

Self Contained Meters contain everything needed for metering within the meter, as the name implies. Self contained meters are limited to 200 A. services, both 1-phase and 3-phase. The only exception in the We Energies service territory is the 320 A. 120/240 Volt, 1-phase meters.

The configurations for self contained meter sockets are shown in Figure 1. The number of terminals, layout of the terminals in the meter socket, and the voltages that use that configuration are shown below.

Self Contained Meter Sockets for Services			
4 Terminal	5 Terminal	5 Terminal	7 Terminal
			
<u>1Ø, 2 WIRE</u> 30 Amp 120 VOLT	<u>1Ø, 3 WIRE</u> 200 Amp 208Y/120 VOLT	<u>3Ø, 3 WIRE</u> 200 amp 480 VOLT*	<u>3Ø, 4 WIRE</u> 200 Amp 208Y/120 VOLT 480Y/277 VOLT
<u>1Ø, 3 WIRE</u> 200 Amp 120/240 VOLT 240/480 VOLT		<u>3Ø, 3 WIRE</u> 200 Amp 240 VOLT Grounded BØ	
<u>1Ø, 3 WIRE</u> 320 Amp 120/240 VOLT		* Has a Sliding Link Disconnect for the center phase	

Figure 1

By-passes are required on all self contained meter sockets. Horn type by-passes are usually used on four terminal 1-phase and five terminal single phase, 208Y/120 Volt, 3-wire meter sockets. Occasionally horn type by-passes will be found on 3-phase meter sockets, but they are generally limited to sockets where lighter loads are anticipated.

Lever operated by-passes are found on most 3-phase meter sockets and 320A. 120/240 Volt 1-phase meter sockets. These by-passes also have a jaw release mechanism which provides a higher clamping force on the blades of the meter to improve the connection.

Transformer rated meter sockets do not require by-pass means.

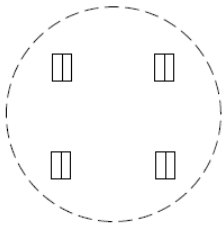
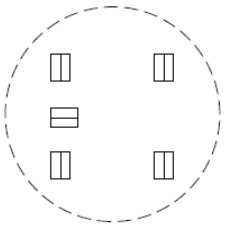
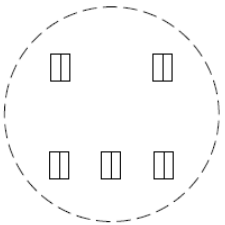
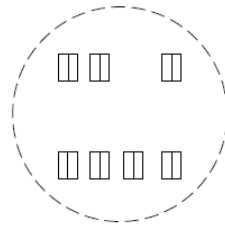
The 480 Volt, 3Ø, 3-Wire Meter Socket is a 5 terminal socket with the 5th terminal in the 6 o'clock position as shown in Figure 1. This socket is also equipped with a sliding link disconnect for disconnecting the center phase when the meter is removed. To operate the link, the retaining bolt is loosened and the link drops down disconnecting the center phase. It should also be noted that generally the manufacturer provides these sockets with a bonding screw or jumper that bonds the center phase to the case. For proper operation of the customer's equipment, it is important to verify that the bonding means has been removed.

Transformer Rated Meters are used for services larger than 320A. These meters require the use of external current transformers. The current transformers are generally located in transockets or could also be in a dedicated compartment in a switchgear unit.

The configurations for transformer rated meter sockets are shown in Figure 2. Again, the number of terminals, layout of the terminals in the meter socket, and the voltages are shown below.

Transformer Rate Meter Sockets for Services 400 – 4000 Amperes		
6 Terminal	8 Terminal	13 Terminal
		
1Ø, 3 Wire 120/240 Volt	3Ø, 3 Wire 240 Volt* 480 Volt	3Ø, 4 Wire 208Y/120 Volt 480Y/277 Volt

Figure 2

Transockets are supplied with the proper transformer rated meter socket by the manufacturer. If the meter socket is not the socket required for the type of service, it usually means the transocket is the wrong unit.

The transformer rated meter sockets are not supplied with other types of current transformer metering installations such as switchgear. For these other types of installations, the transformer rated meter socket must be supplied separately by the customer.

As with all electrical installations, it must be verified that the metering equipment is correct for the voltage and type of service. We hope you find this information useful. Should you have any questions regarding a service installation, please contact your local We Energies job representative.

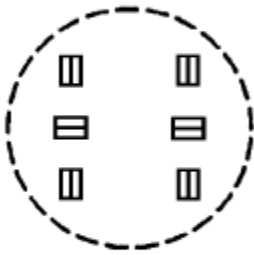
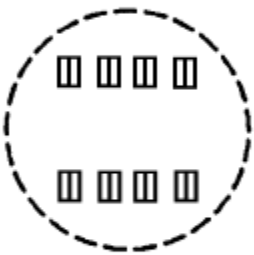
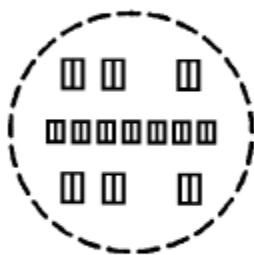
Helpful links on the We Energies website:

Energy Service for New Construction: http://www.we-energies.com/residential/new_construction/index.htm

Customer Owned Generation: http://www.we-energies.com/business/altenergy/custgen_wisc.htm

APPENDIX RESIDENTIAL DECK PROCEDURE

1. When building a deck, service entrance equipment must remain accessible at all times. This procedure is on how to deal with problems once decks are built around meters.
2. **Avoid installing the deck around the service entrance equipment.** If a deck is built over a service lateral and a fault on the service lateral occurs, outage times may be long and costly to repair. The Company must be able to safely work on its equipment. The National Electric Code, NEC, Article 110 *Requirements for Electrical Installations* requires the follow working space clearances be met.
 - a. *110.26(A)(1) Depth of Working Space:* A 3 ft. minimum from the front or opening of the enclosure containing live parts shall remain clear.
 - b. *110.26(A)(2) Width of Working Space:* Width of working space in front of electrical equipment shall be the width of the equipment or 30 in., whichever is greater.
 - c. *110.26(A)(3) Height of Working Space:* The work space shall be clear and extend from the grade to 6½ ft.

Option 1

Move meter pedestal to the edge of the deck and mount against a treated wood post. Service entrance cable can be installed in conduit under the deck and back to the dwelling.

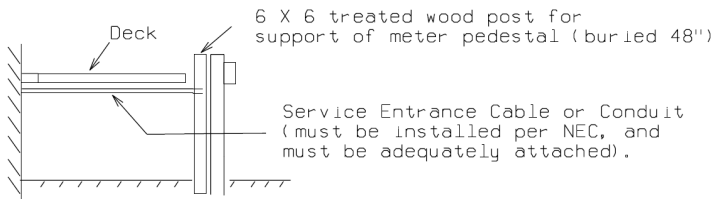

Option 2

Move meter pedestal to the edge of the deck and mount against a treated wood post. Service entrance cable can be direct buried under the deck and back to the dwelling. Marking tape is required in Michigan for cable protection [NEC 300.5(D)] but not required for Wisconsin per COMM 16.300(2).

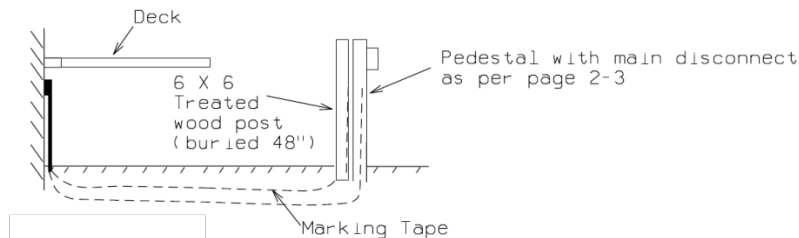

Option 3

Move meter pedestal to an area on the house away from the deck. The service entrance conduit or cable can then go around the house to the old service pedestal site. Marking tape is required in Michigan for cable protection [NEC 300.5(D)] but not required for Wisconsin per COMM 16.300(2).

APPENDIX

METER PROTECTION FROM SNOW AND ICE

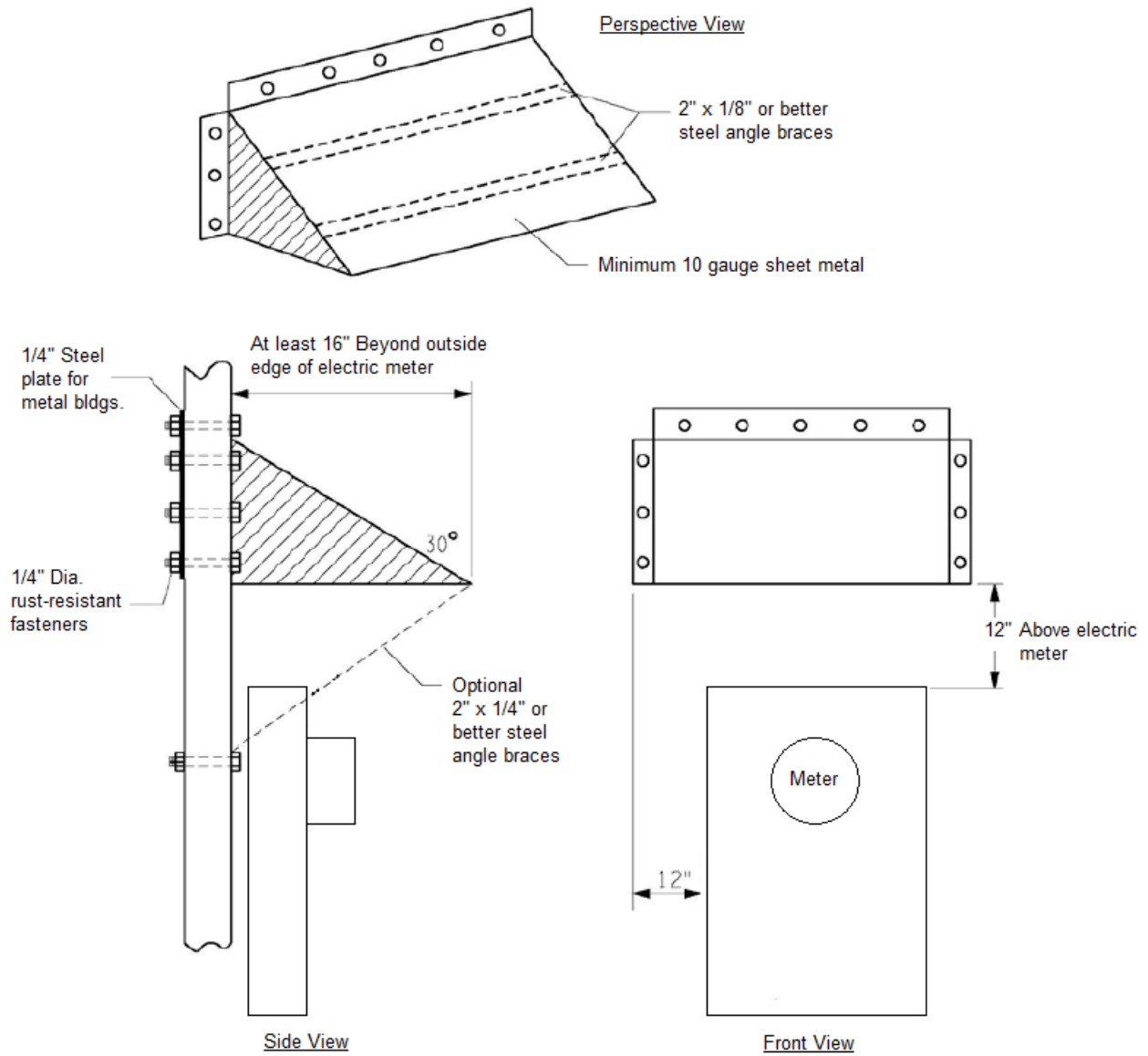

APPENDIX

CHOOSING THE PROPER METER SOCKET

In the Metering Devices book (Book 2 Section D), meter sockets are listed by the number of terminals. The intent of this article is to help the installer verify that the correct meter socket is installed. The type of meter socket is determined by the voltage, number of conductors, if the service is 1-phase or 3-phase, and the size of the service.

Types of Meters

Meters can be broken into two types: Self Contained and Transformer Rated.

Self Contained Meters contain everything needed for metering within the meter, as the name implies. Self contained meters are limited to 200 A. services, both 1-phase and 3-phase. The only exception in the We Energies service territory is the 320 A. 120/240 Volt, 1-phase meters.

The configurations for self contained meter sockets are shown in Figure 1. The number of terminals, layout of the terminals in the meter socket, and the voltages that use that configuration are shown below.



Self Contained Meter Sockets for Services 30 – 200 Amperes			
4 Terminal	5 Terminal	5 Terminal	7 Terminal
			
<u>1Ø, 2 Wire</u> 120 Volt	<u>1Ø, 3 Wire</u> 208Y/120 Volt	<u>3Ø, 3 Wire</u> 480 Volt*	<u>3Ø, 4 Wire</u> 208Y/120 Volt 480Y/277 Volt
<u>1Ø, 3 Wire</u> 120/240 Volt 240/480 Volt		<u>3Ø, 3 Wire</u> 240 Volt* *Grounded BØ	
<u>1Ø, 3 Wire</u> 320 Ampere 120/240 Volt		* Has a Sliding Link Disconnect for the center phase	

Figure 1

By-passes are required on all self contained meter sockets. Horn type bypasses are usually used on four terminal 1-phase and five terminal single phase, 208Y/120 Volt, 3-wire meter sockets. Occasionally horn type by-passes will be found on 3-phase meter sockets, but they are generally limited to sockets where lighter loads are anticipated.

Lever operated by-passes are found on most 3-phase meter sockets and 320A. 120/240 Volt 1-phase meter sockets. These by-passes also have a jaw release mechanism which provides a higher clamping force on the blades of the meter to improve the connection.

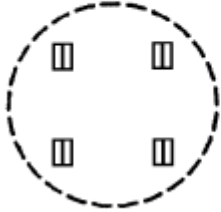
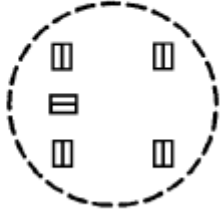
Transformer rated meter sockets do not require by-pass means.

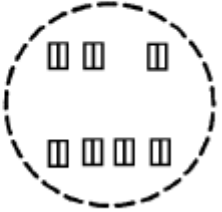
The 480 Volt, 3Ø, 3-Wire Meter Socket is a 5 terminal socket with the 5th terminal in the 6 o'clock position as shown in Figure 1. This socket is also equipped with a sliding link disconnect for disconnecting the center phase when the meter is removed. To operate the link, the retaining bolt is loosened and the link drops down disconnecting the center phase. It should also be noted that generally the manufacturer provides these sockets with a bonding screw or jumper that bonds the center phase to the case. For proper operation of the customer's equipment, it is important to verify that the bonding means has been removed.

Transformer Rated Meters are used for services larger than 320A. These meters require the use of external current transformers. The current transformers are generally located in transockets or could also be in a dedicated compartment in a switchgear unit.

The configurations for transformer rated meter sockets are shown in Figure 2. Again, the number of terminals, layout of the terminals in the meter socket, and the voltages are shown below.

Transformer Rate Meter Sockets for Services 400 – 4000 Amperes		
<u>6 Terminal</u>	<u>8 Terminal</u>	<u>13 Terminal</u>
		
<u>1Ø, 3 Wire</u> 120/240 Volt	<u>3Ø, 3 Wire</u> 240 Volt* 480 Volt	<u>3Ø, 4 Wire</u> 208Y/120 Volt 480Y/277 Volt

Figure 2

Transockets are supplied with the proper transformer rated meter socket by the manufacturer. If the meter socket is not the socket required for the type of service, it usually means the transocket is the wrong unit.

The transformer rated meter sockets are not supplied with other types of current transformer metering installations such as switchgear. For these other types of installations, the transformer rated meter socket must be supplied separately by the customer.

As with all electrical installations, it must be verified that the metering equipment is correct for the voltage and type of service. We hope you find this information useful. Should you have any questions regarding a service installation, please contact your local We Energies job representative.

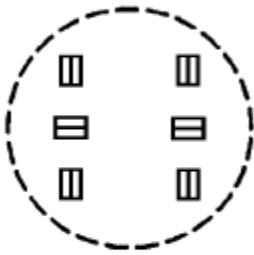
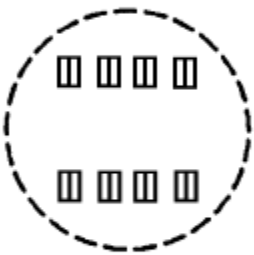
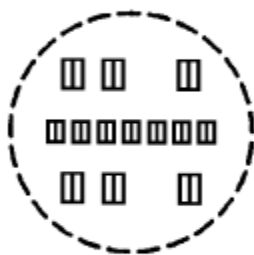
Helpful links on the We Energies website:

Energy Service for New Construction: http://www.we-energies.com/residential/new_construction/index.htm

Customer Owned Generation: http://www.we-energies.com/business/altenergy/custgen_wisc.htm

APPENDIX RESIDENTIAL DECK PROCEDURE

1. When building a deck, service entrance equipment must remain accessible at all times. This procedure is on how to deal with problems once decks are built around meters.
2. **Avoid installing the deck around the service entrance equipment.** If a deck is built over a service lateral and a fault on the service lateral occurs, outage times may be long and costly to repair. The Company must be able to safely work on its equipment. The National Electric Code, NEC, Article 110 *Requirements for Electrical Installations* requires the follow working space clearances be met.
 - a. *110.26(A)(1) Depth of Working Space:* A 3 ft. minimum from the front or opening of the enclosure containing live parts shall remain clear.
 - b. *110.26(A)(2) Width of Working Space:* Width of working space in front of electrical equipment shall be the width of the equipment or 30 in., whichever is greater.
 - c. *110.26(A)(3) Height of Working Space:* The work space shall be clear and extend from the grade to 6½ ft.

Option 1

Move meter pedestal to the edge of the deck and mount against a treated wood post. Service entrance cable can be installed in conduit under the deck and back to the dwelling.

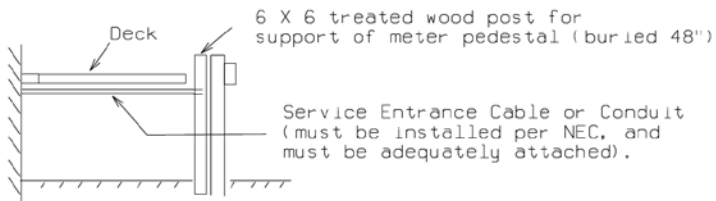

Option 2

Move meter pedestal to the edge of the deck and mount against a treated wood post. Service entrance cable can be direct buried under the deck and back to the dwelling. Marking tape is required in Michigan for cable protection [NEC 300.5(D)] but not required for Wisconsin per COMM 16.300(2).

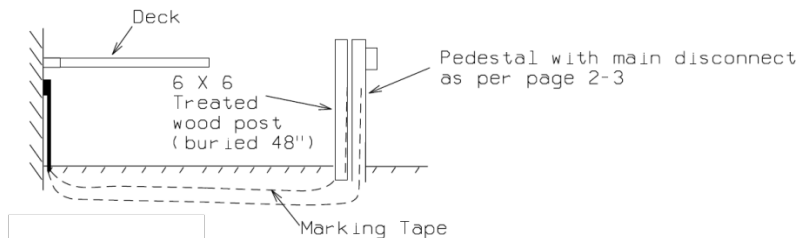

Option 3

Move meter pedestal to an area on the house away from the deck. The service entrance conduit or cable can then go around the house to the old service pedestal site. Marking tape is required in Michigan for cable protection [NEC 300.5(D)] but not required for Wisconsin per COMM 16.300(2).

APPENDIX

METER PROTECTION FROM SNOW AND ICE

